

# Cyber RISKS!

## Dr. Ananth Prabhu G

BE, MBA, MTech, DCL, PhD, Post Doctoral Fellow  
Professor & Principal Investigator- Cyber Sec and  
Digital Forensics CoE, Sahyadri

Cyber Law Trainer- Karnataka Judicial Academy

Cyber Security Trainer- Karnataka Police Academy

Director- SUREPASS Academy



**Pray for  
KARNATAKA**





↻ Random Location

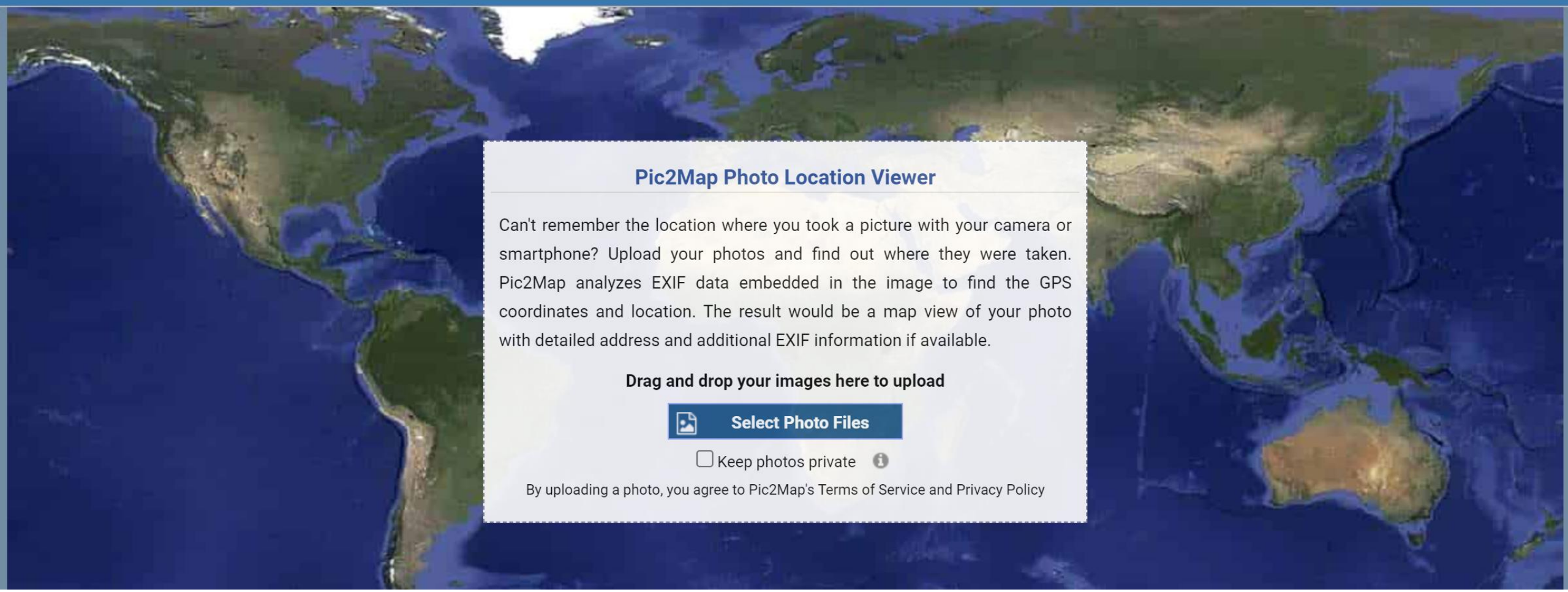

### Pic2Map Photo Location Viewer

Can't remember the location where you took a picture with your camera or smartphone? Upload your photos and find out where they were taken. Pic2Map analyzes EXIF data embedded in the image to find the GPS coordinates and location. The result would be a map view of your photo with detailed address and additional EXIF information if available.

**Drag and drop your images here to upload**

 **Select Photo Files**

Keep photos private 

By uploading a photo, you agree to Pic2Map's Terms of Service and Privacy Policy







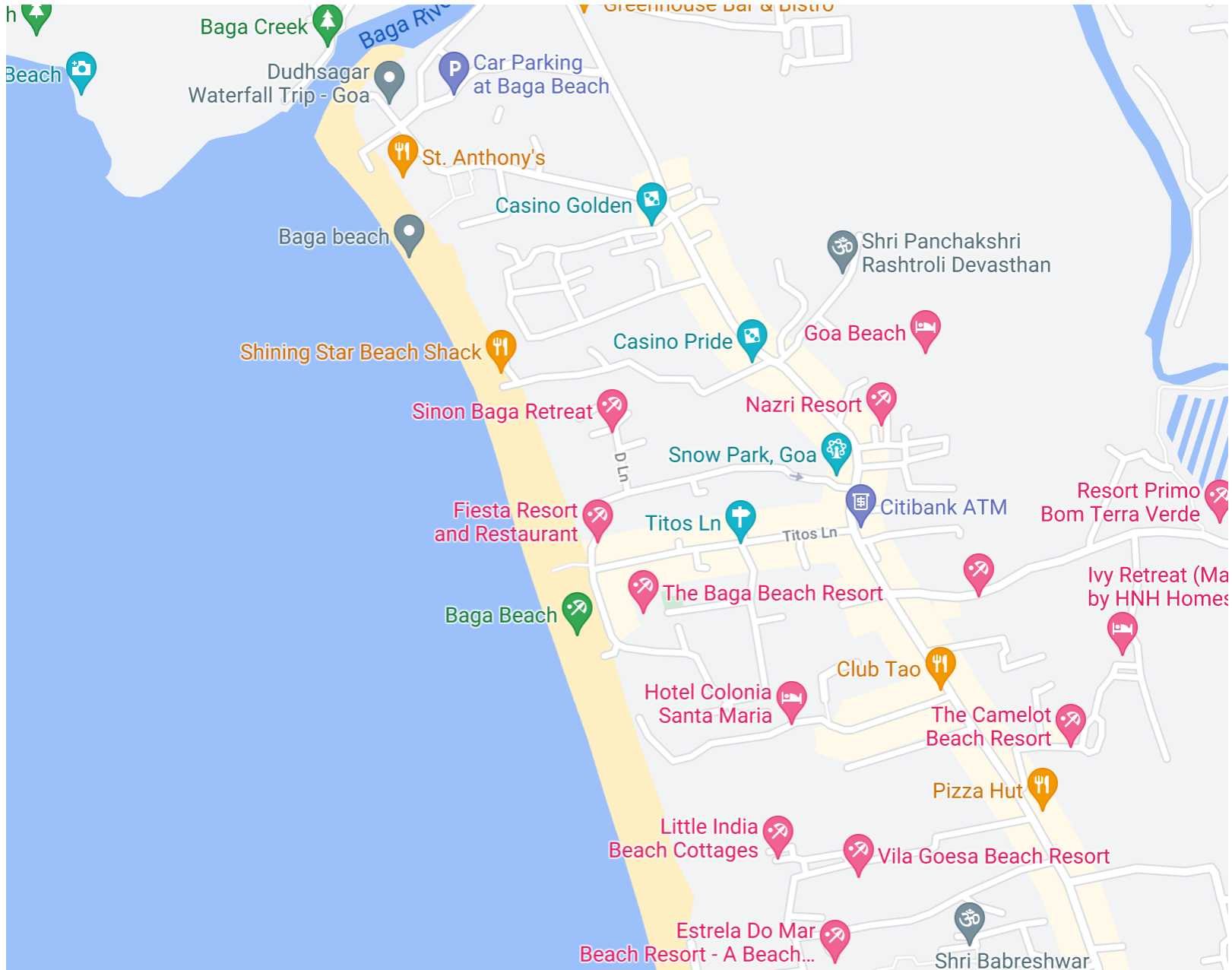







nehakakkar 

[Follow](#)

2,083 posts

57.1m followers

428 following

**Neha Kakkar (Mrs. Singh)**

Blessed! ❤️🙏 Living My Dream 😊

Matlabi Yariyan Unplugged 😊👉

[youtu.be/kCKMfYr\\_bYE](https://youtu.be/kCKMfYr_bYE)



NehuPreet...

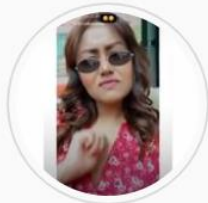

MxTakatak...



Fashion 🔥🇮🇳



DeepuSun...



SweetHom...

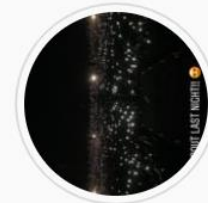

NehaKakka...

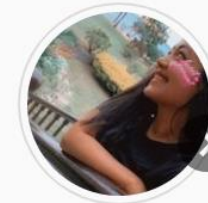

Travel 🌍

# Surface Web is only the Tip of the Iceberg

## SURFACE WEB

Google, Yahoo, Naver, Yandex, Wikipedia, Reddit, ...

5 %



## DEEP WEB

Cloud Storage, Patent Data, Research Articles, Legal Documents, Financial Records, ...

95 %

## DARK WEB

Onion Sites, Hidden Marketplaces, Anonymous Journalism, ...

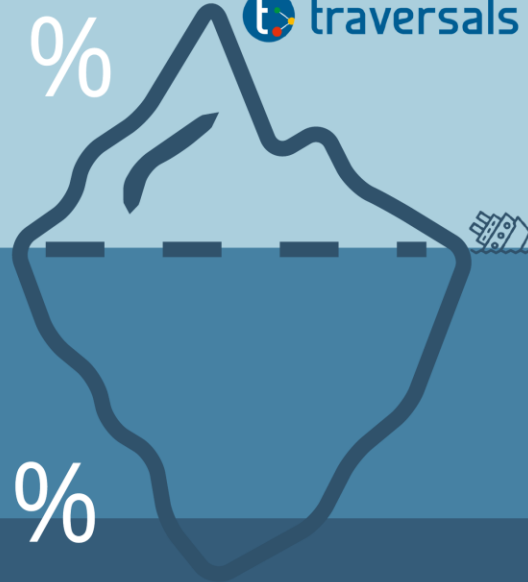





**Which is the third  
largest economy**





**1. USA**

**2. CHINA**

**3. ????????**

**?**

# Global Cybercrime Damage Costs:

- **\$6 Trillion USD a Year.** \*
- **\$500 Billion a Month.**
- **\$115.4 Billion a Week.**
- **\$16.4 Billion a Day.**
- **\$684.9 Million an Hour.**
- **\$11.4 Million a Minute.**
- **\$190,000 a Second.**



ALL FIGURES ARE  
PREDICTED BY 2021

\* SOURCE: CYBERSECURITY VENTURES



**We have already spoken for 9 minutes  
and the damages globally for now is  
ONLY**

**100 Million Dollars**



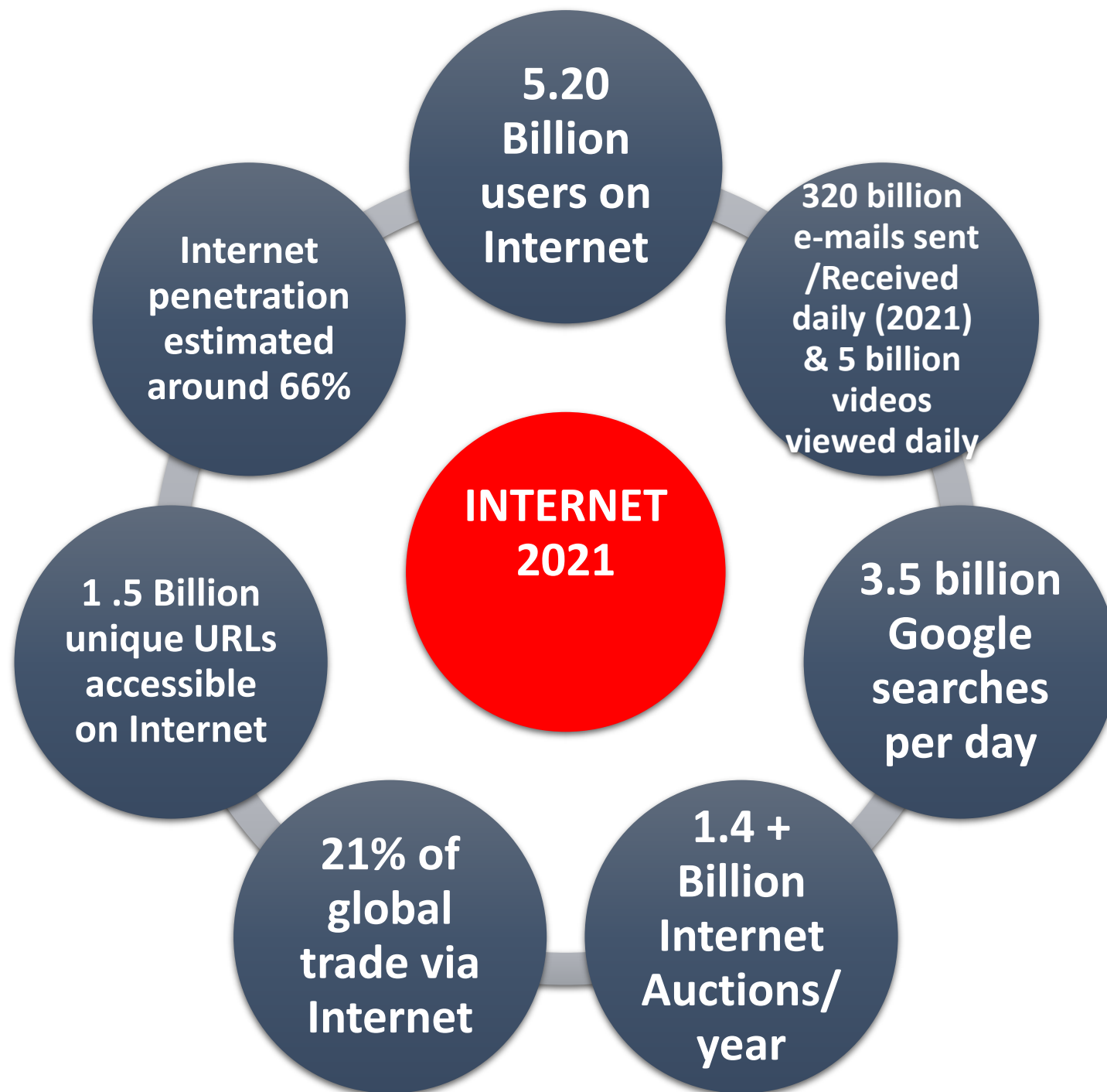

# Global Number of Connected IoT Devices

Number of global active IoT Connections (installed base) in Bn

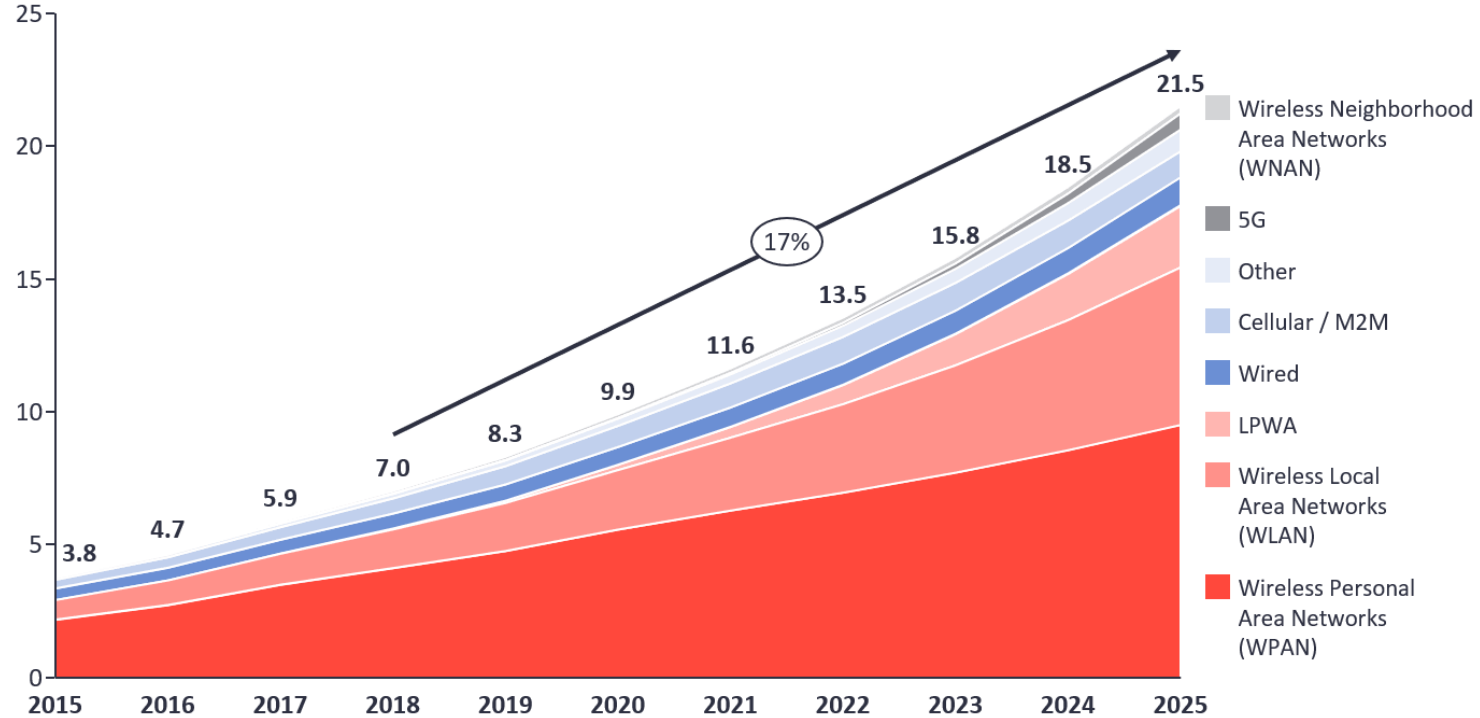

Note: IoT Connections do not include any computers, laptops, fixed phones, cellphones or tablets. Counted are active nodes/devices or gateways that concentrate the end-sensors, not every sensor/actuator. Simple one-directional communications technology not considered (e.g., RFID, NFC). Wired includes Ethernet and Fieldbuses (e.g., connected industrial PLCs or I/O modules); Cellular includes 2G, 3G, 4G; LPWAN includes unlicensed and licensed low-power networks; WPAN includes Bluetooth, Zigbee, Z-Wave or similar; WLAN includes Wi-fi and related protocols; WNAN includes non-short range mesh; Other includes satellite and unclassified proprietary networks with any range.

Source: IoT Analytics Research 2018

# Percentage of Global Mobile Traffic, 2011-2021

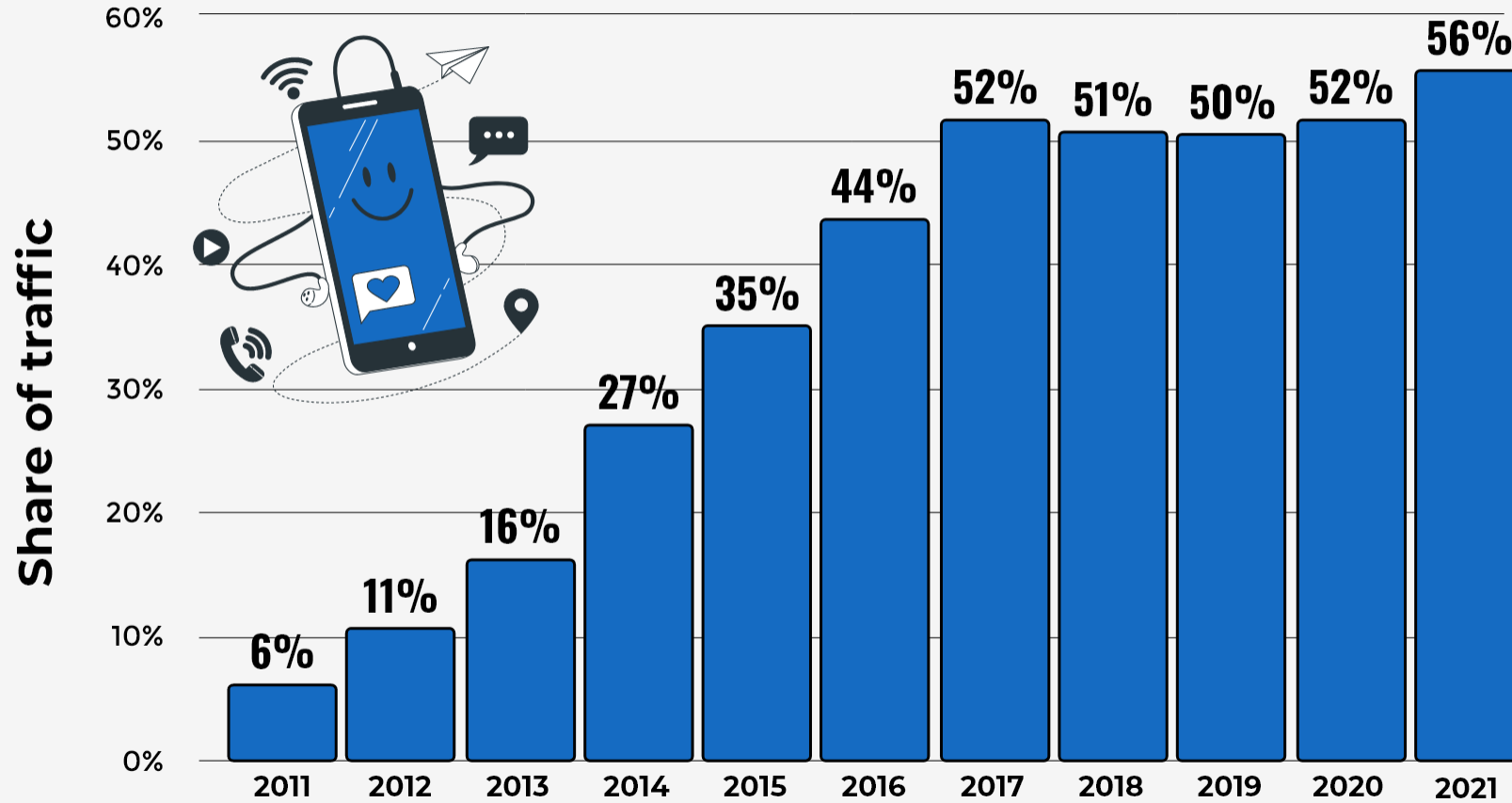



1<sup>st</sup> Gen



1980s

Viruses

2<sup>nd</sup> Gen



1990s

Network Threats

3<sup>rd</sup> Gen



2000s

Application Threats

4<sup>th</sup> Gen



2010s

Payloads

5<sup>th</sup> Gen



Present

Mega Threats

# Types of Cybercrime

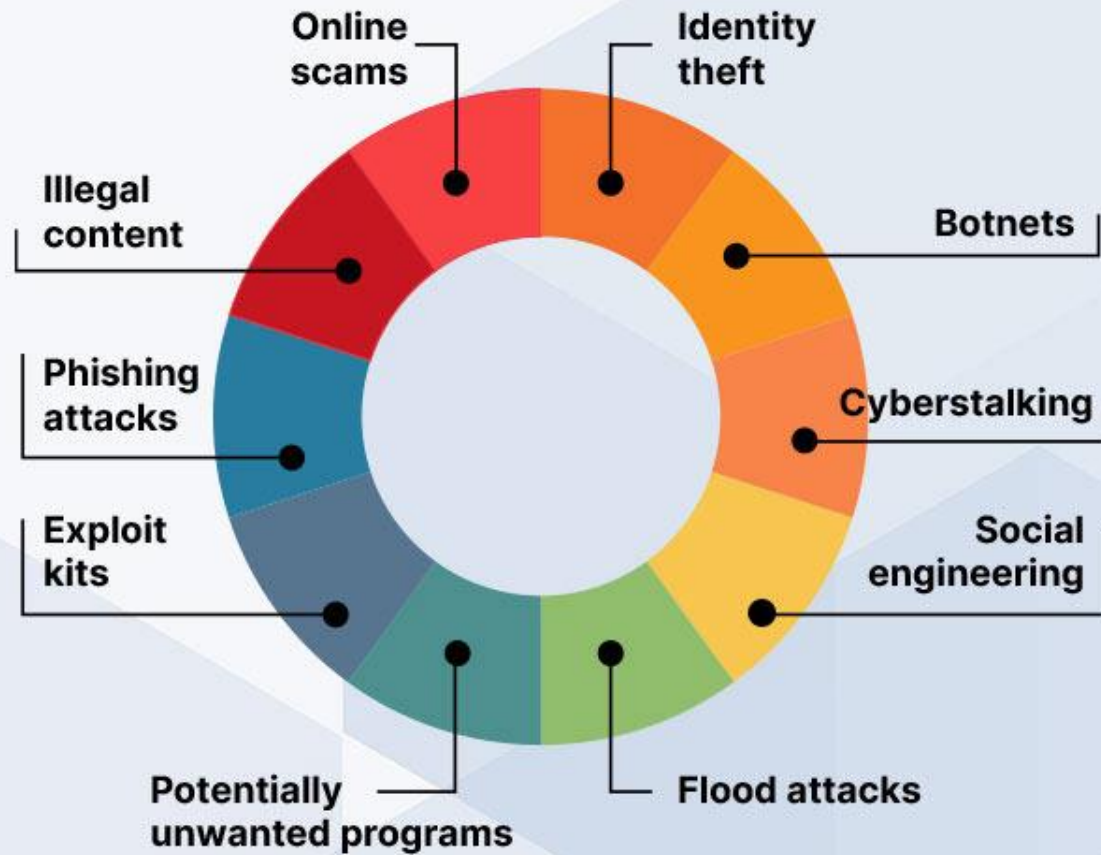

SecurityTrails

# 5 Types of Cyber Criminals



The Social Engineer



The Spear Phisher



The Hacker



The Rogue Employee



The Ransom Artist





**COVID19 Tip**

Respect the real heroes who are helping you during COVID-19 pandemic situation.

**Security Tip**

Respect the privacy of others just as you expect the same from them.



**COVID19 Tip**

Refer government authorised sources for COVID-19 updates and news.

**Security Tip**

Refer authorised sources for downloading genuine app.



**COVID19 Tip**

Clean and disinfect your belongings after you reach home to secure your family from COVID-19.

**Security Tip**

Clear cookies and delete browsing history at end of session and stay safe.



**COVID19 Tip**

Include superfoods in your diet to boost your immunity and fight against COVID-19.

**Security Tip**

Pay extra attention when using public Wi-Fi, and avoid making payments while you are on unprotected Wi-Fi.



**COVID19 Tip**



**COVID19 Tip**

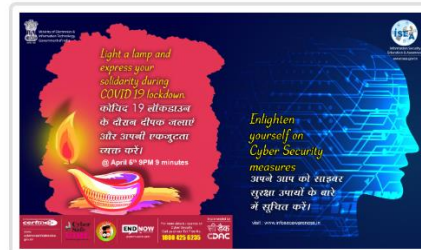

**COVID19 Tip**



**COVID19 Tip**



### Dose 1



### Dose 2



Ensure taking both the vaccine shots to sufficiently prepare your immune system to effectively fight against COVID-19 virus as per Government guidelines  
 कोविड-19 वायरस से प्रभावी रूप से लड़ने के लिए अपनी प्रतिरक्षा प्रणाली को पर्याप्त रूप से तैयार करने के लिए दोनों वैक्सीन शॉट्स लेना सुनिश्चित करें।



www.cyberswachhtakendra.gov.in



For more details / queries on Cyber Security  
 Call us on our Toll free No.  
**1800 425 6235**

Implemented by



Information Security  
 Education & Awareness  
 www.isea.gov.in



Ensure updating your software with required patches and install regular updates to avoid dangers of software vulnerabilities and security issues  
 आवश्यक पैच के साथ अपने सॉफ्टवेयर को अपडेट करना सुनिश्चित करें और सॉफ्टवेयर भेद्यता और सुरक्षा समस्याओं के खतरों से बचने के लिए नियमित अपडेट स्थापित करें।

For more details visit :  
 www.**InfoSec**  
 awareness.in





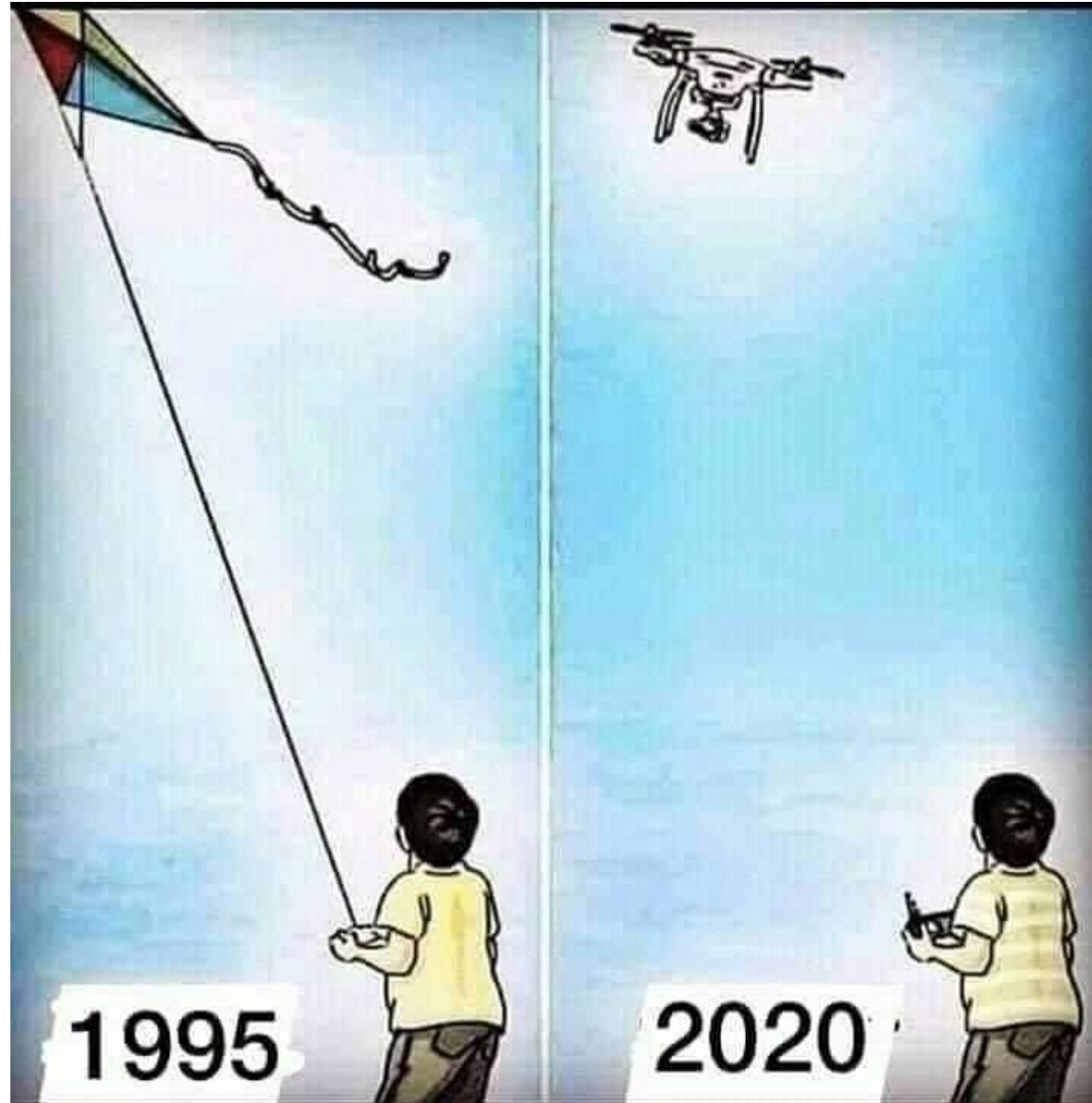



# Coronavirus lockdown: Drone delivers pan masala in Gujarat. Video goes viral

*A video of pan masala getting delivered using a drone in Morbi, a town in Gujarat has gone viral on the internet.*

ADVERTISEMENT



India Today Web Desk [Twitter](#)

New Delhi

April 12, 2020 UPDATED: April 12, 2020 20:08 IST



Drone delivers pan masala in Gujarat Photo: Instagram

ksdk.com



'Peeping drone' spies on girls in bathroom





# New Generation Spy Devices





Courtesy of ATN

**BUY: SUPERIOR TACTICAL PVS-7 GOGGLES \$2,095.00**

**BUY IT**





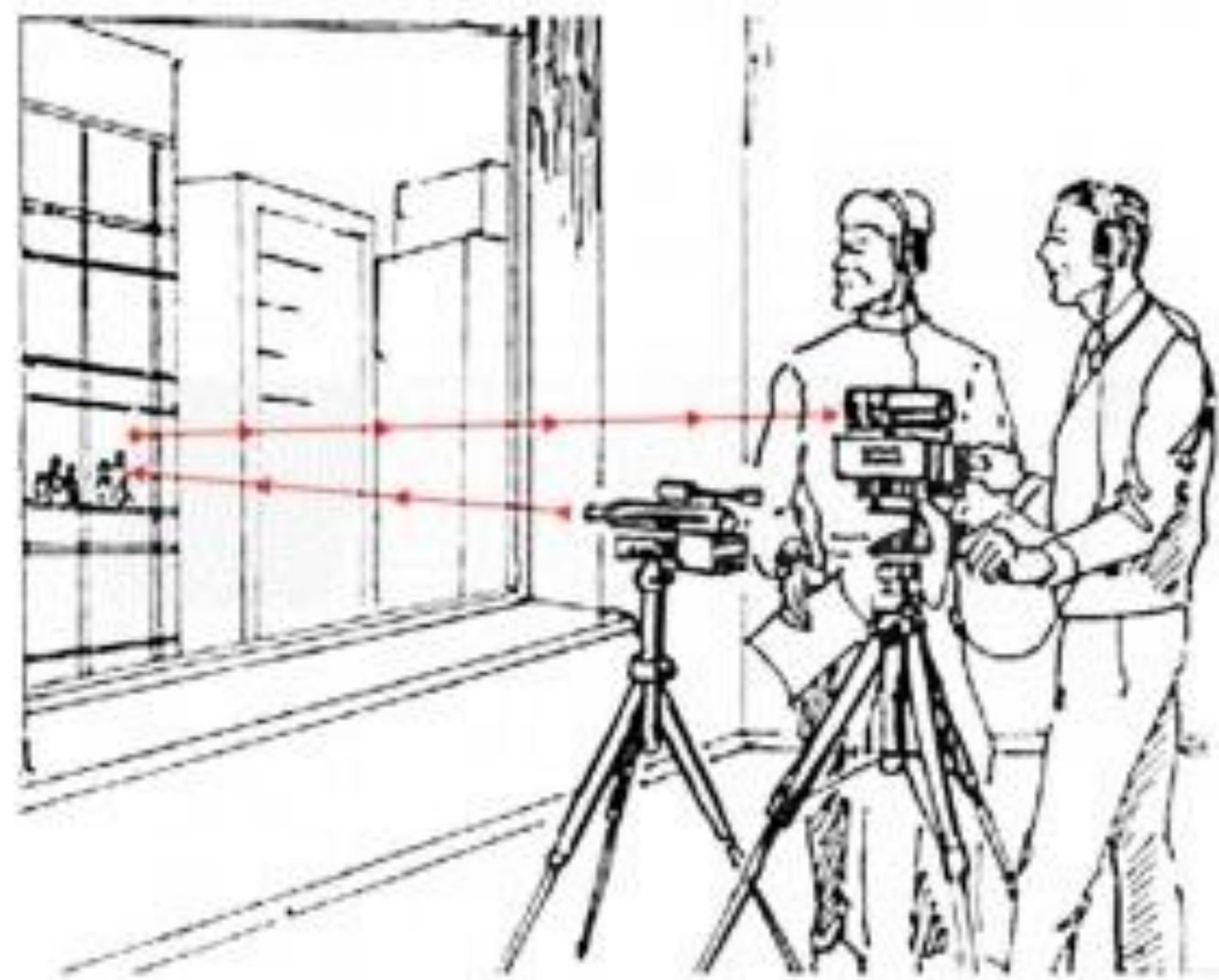

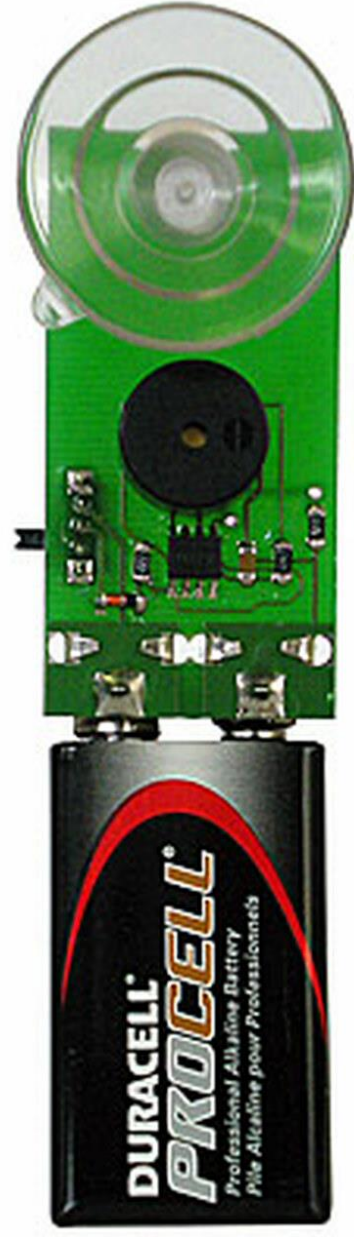

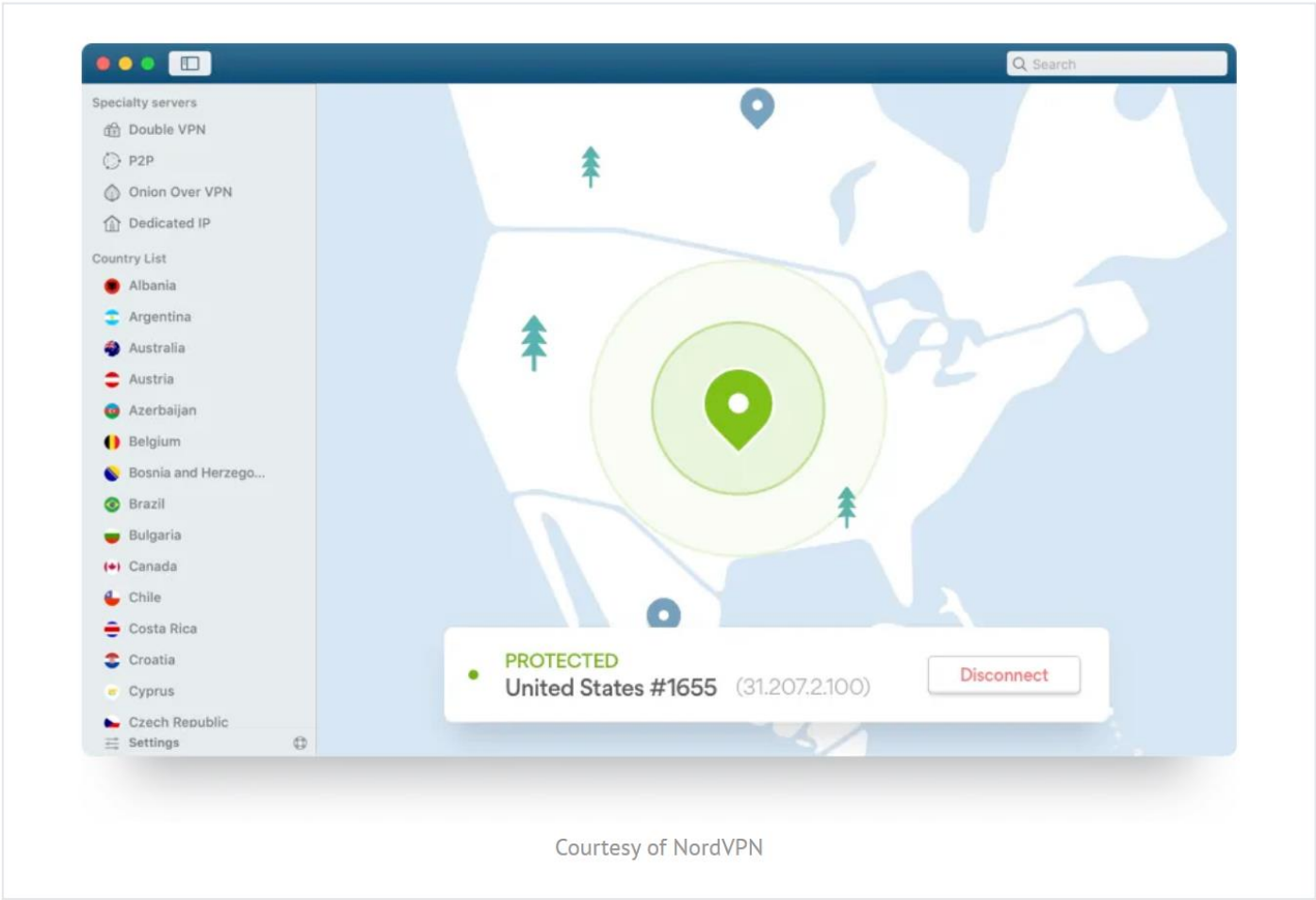

Courtesy of NordVPN

**BUY: NORDVPN SUBSCRIPTION \$11.95/MONTH**

**BUY IT**



Courtesy of Amazon







Courtesy of Amazon

**BUY: SPY FINDER PRO \$148.00**

**BUY IT**



Courtesy of Amazon

BUY: JMDHKK M8000 AI RF DETECTOR **\$189.00**

BUY IT



Courtesy of Amazon

**BUY: FLIR ONE PRO LT (IOS) \$249.00**

**BUY IT**

**BUY: FLIR ONE PRO LT (ANDROID) \$299.99**

**BUY IT**





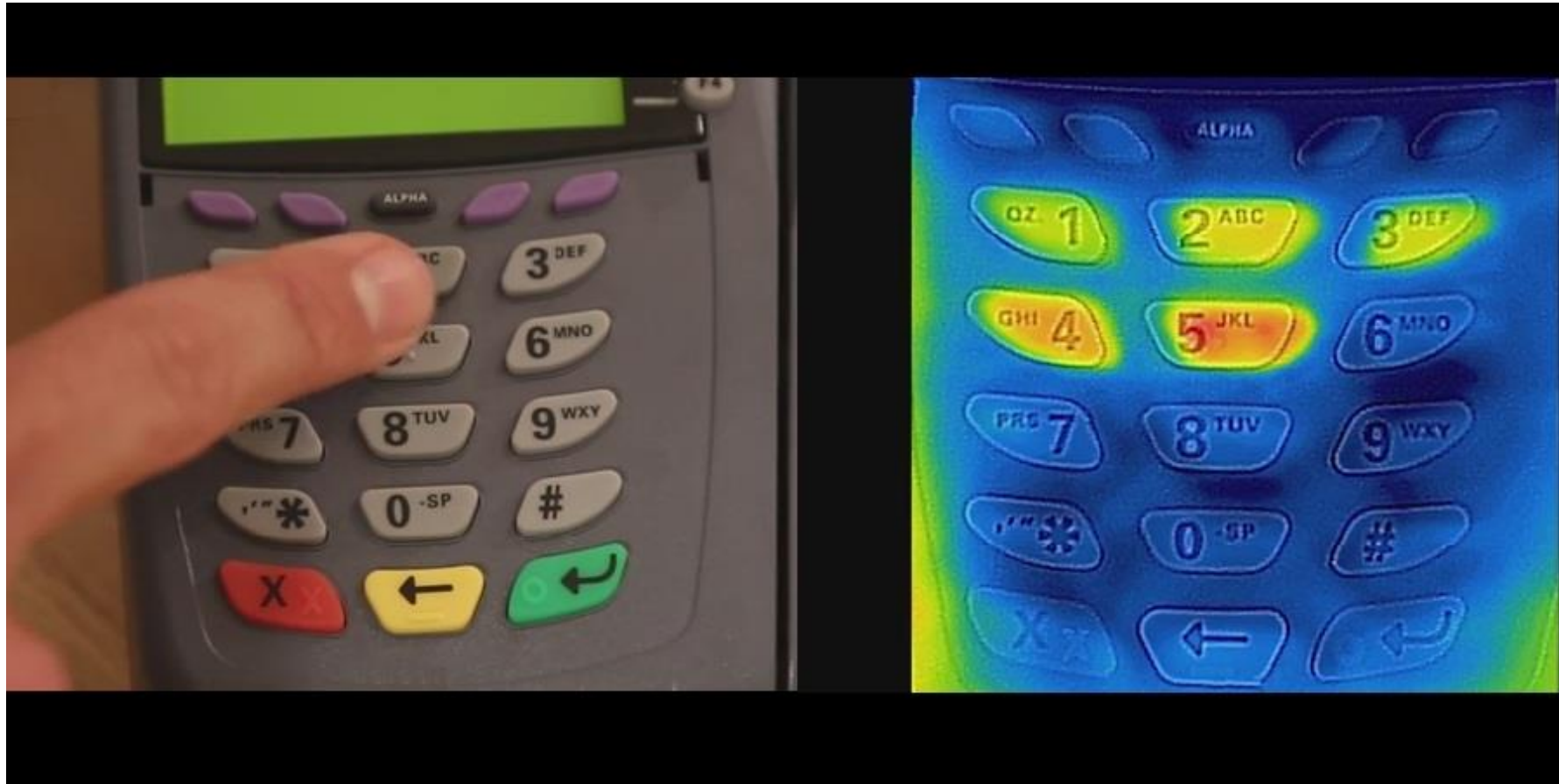



Courtesy of Amazon

**BUY: KINGSTON IRONKEY S1000 \$129.54**

**BUY IT**





FREE  
Headphone







CDMA 

GSM

3G 

4G LTE 



WiFi

 GPS

LO JACK 













**COVID-19 IMPACT**

**ON CYBERCRIME**





**BREAKING NEWS**

# Fake Oximeter App to Steal Mobile Data





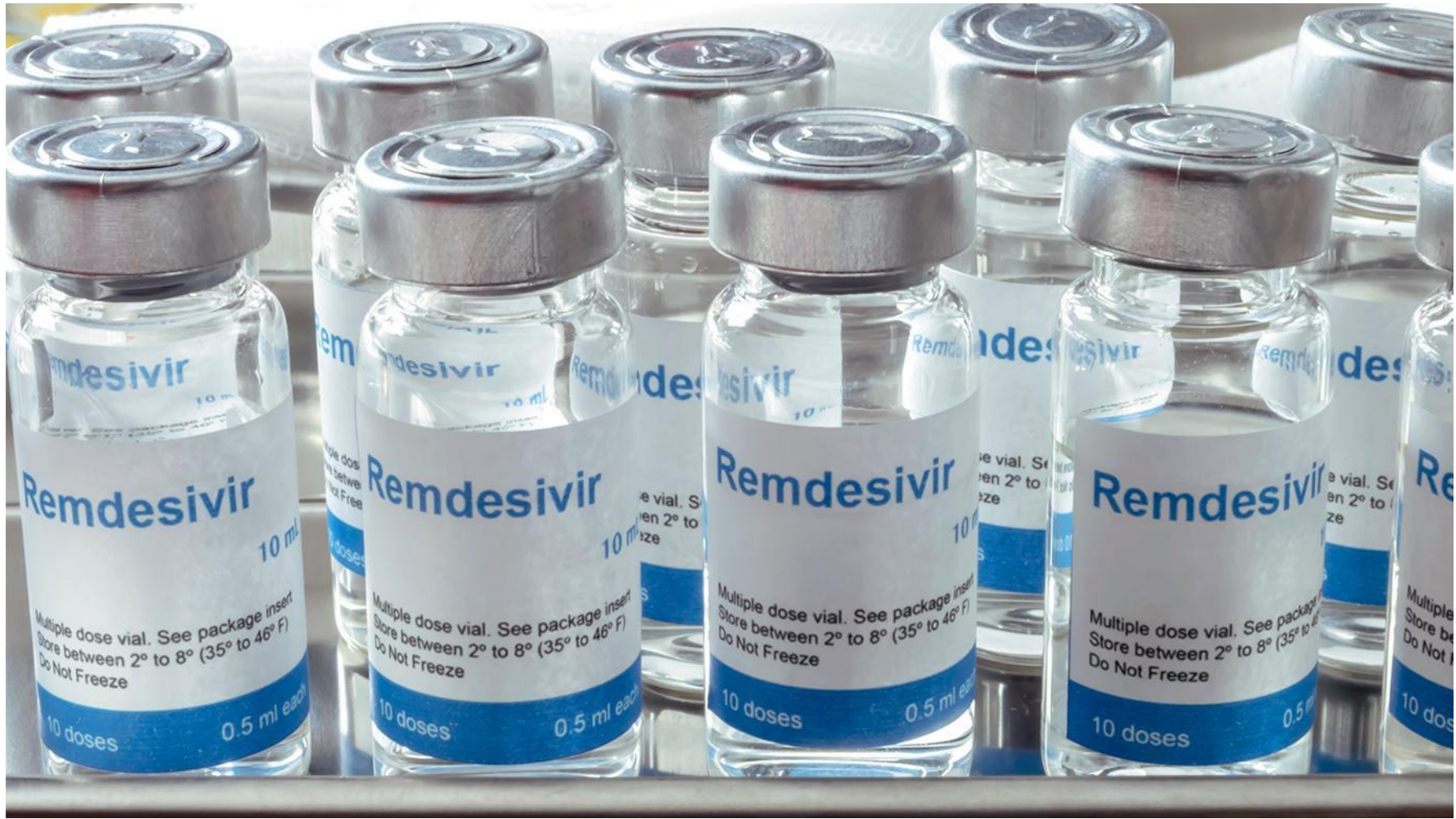

# OTP Fraud Call !!!







Appointment for vaccination



click to

Covid-19 INDIA as on :  
January 2021, 08:00  
(IST+5:30)Daily change since  
(17)

Active

142562 (1051↑)

Discharged

10573372 (11764↑)

Deceased

155,000 (108↑)

Covid-19 Vaccination

Total Vaccination : 70,17,114 (4,05,345↑)

FAKE

FAKE

FAKE



 Top stories



**INDIA<sup>TV</sup>**

Sonu Sood notifies followers about fake COVID-19 donation campaign in his name

1 day ago



**The Tribune**

Sonu Sood notifies followers about fake Covid-19 donation campaign in his name

1 day ago



**FIRSTPOST.**

Sonu Sood warns people about fake COVID-19 donation campaign under his...

22 hours ago



[View all](#)

# Alert ! OTP Fraud LOAN EMI Moratorium

सावधान ! कहीं आपका  
LOAN EMI टालना  
आपका खाता खाली तो  
नहीं कर देगा ।



# CYBER SAFETY CHECKLIST



Back up online and offline files regularly and securely



Strengthen your home network



Use strong passwords



Keep your software updated



Manage social media profiles



Check privacy and security settings



Avoid opening and delete suspicious emails or attachments



INTERPOL

BE VIGILANT . BE SKEPTICAL . BE SAFE



# GOOD CYBER HYGIENE

#WashYourCyberHands

of ransomware



INTERPOL



**NOTHING BAD IS GOING  
TO HAPPEN TO ME**

**Hacking is the new  
Normal**

**Sanjay Sahay**



DON'T TRY THIS UNLESS YOU LOVE INDIAN JAILS





# Cyber Crime

- Cyber crime is defined as a crime in which a **Digital communication Device** is the **object** of the crime, or used as a **tool / target** or used **incidental** or as a **witness** to commit an **offence**.
- Cybercriminals may use Information technology to access personal information, business trade secrets or use the internet for exploitive or malicious purposes.

# Cybercrime

---

- **Global in Character** - The whole world could be the crime scene in a cybercrime.
- **Intangible evidence** - The evidence may have been erased, damaged or secreted/Encrypted. Correct facts may not come to light.
- **Silent in Nature** - There are no signs of physical violence or struggle at the scene of crime
- **Substantial Losses** – Cyber Crime losses are huge. Bank frauds value-wise and volume-wise have increased substantially. Its impact is severe and it may be a long term.



2010



2020

**In just 10 years camera man & pilot both  
lost their jobs. UPGRADE YOURSELF**

## How to attend Online Class :

Step 1 : 

Step 2 : 

Step 3 :









Online classes  
behind the camera. 😂









One last pic before I go to sleep!



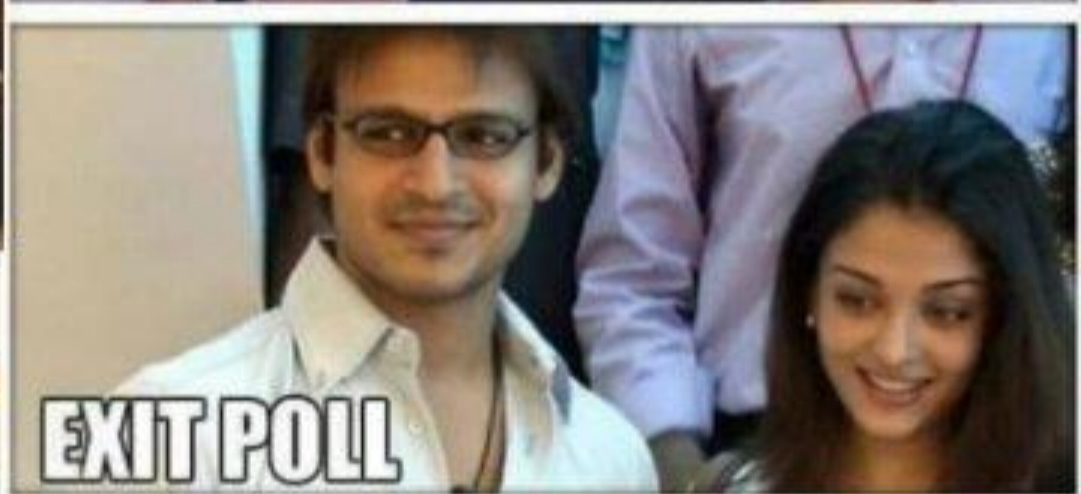

# Chat Applications

## Safest

-  SilentCircle
-  Redphone
-  OSTel
-  ChatSecure
-  SignalChat

## Safe

-  Telegram
-  Wickr
-  Threema
-  Surespot

## Moderate Safe

-  CoverMe
-  BBM
-  iMessage
-  FaceTime
-  Hangouts
-  Facebook Messenger

## Unsafe

-  Viber
-  WhatsApp
-  LINE
-  Tango
-  ooVoo
-  Kakao Talk
-  WeChat
-  IM+Pro
-  Nimbuzz
-  Hike
-  Chat ON
-  Kik
-  Voxer
-  imo
-  GroupMe









## Email Boarding Pass ( Web Check in )



GoIndiGo.In

Don't be late, your flight won't wait



Name **[REDACTED]**  
From **Delhi**      ✈      **Jaipur**  
Flight No. **6E 5098**      Date **30 Nov 19**  
Boarding Time **05:35 AM**      Departure Time **06:20 AM**  
Sequence No. **1**      Class **R**  
Gate No.      Seat No. **15E**

Boarding gate closes 25 minutes prior to the departure time. Boarding gate numbers are subject to change please check the flight information screen for latest updates. Checking of photo id and hand baggage is a mandatory procedure. Passengers are requested to cooperate with IndiGo and the relevant authorities. Have a pleasant flight. Call 0 99 10 28 38 38 / 0124 961 3638

### SPECIAL SERVICES

**NIL**

Name : MS SS TEST  
PNR : **QJRD8N**  
Fit No. : **6E 5098**  
Seat No. : **15E**  
Seq No. : **1**

### MS Anshika Mittal

From **Delhi**  
✈ **Jaipur**  
Flight No. **6E 5098**  
Date **15 May 19**  
Boarding Time **05:35 AM**  
Departure Time **06:20 AM**  
Seq No. **1**      Class **R**  
Gate No      Seat No **15E**



# ReadMyBoP - Read My Boarding Pass

[www.bighugesystems.com](http://www.bighugesystems.com) Travel & Local

★★★★★ 33

3+

 This app is compatible with all of your devices.

 Add to Wishlist

Install

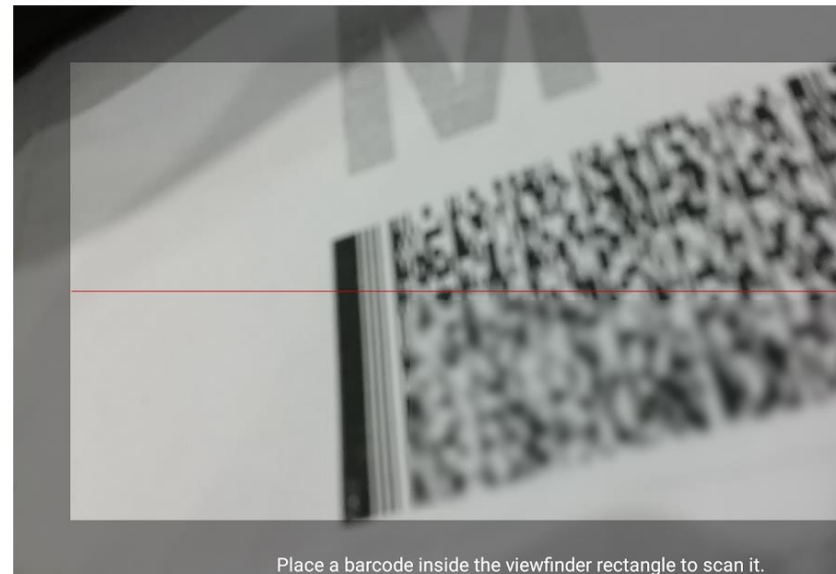

- A. Gender
- B. Which passenger number in the ticket
- C. Passenger Last name
- D. Passenger First name
- E. Ticket Type (Online/Physical)
- F. PNR
- G. Source
- H. Destination
- I. Flight Carrier
- J. Flight Number
- K. Passenger Seat Class
- L. Seat Number
- M. Flight Sequence Number
- N. Passenger Clearance Status
- O. Passenger Checked IN/Not
- P. What document type this is
- Q. Where this document was printed ar airport or somewhere else
- R. Printed
- S. Flight Date
- T. Document issuing Flight company
- U. Document is authorised or not









**Beware  
before you scan QR  
code**



# FILL UP & GO HERE

WITH OUR SPEEDY PAYMENT SERVICE

Powered by  PayPal



0557#02

SCAN OR ENTER CODE FROM YOUR CAR TO PAY

# 0557#02

NOT SET UP? PICK UP A LEAFLET IN STORE

HERE'S TO KEEPING BRITAIN MOVING







# DIGITAL FOOTPRINTS

What do yours say?

## BE CAREFUL ABOUT:

- What you share.
- Where you share.
- With whom you share.

## BE SMART ABOUT:

- Sites you visit.
- Emails you open.
- Links you click.

**BE YOURSELF**  
but be your best self.



# Room No 632

**K.R.Ramamoorthi**



**26-11-2008**

# Google

- **Google knows you better than you know about yourself!**
- **Google does not forget**
- **Google does not delete**
- **Over 271 Google Products & Services You Probably Don't Know**

# Google My Activity

- <https://myactivity.google.com/myactivity>
- **1. Activity controls**
- **2. Web & App Activity**
- **3. Location History**
- **4. Device Information**
- **5. Voice & Audio Activity**
- **6. YouTube Search History**
- **7. YouTube Watch History**



# Privacy...

- **You are not the Customer**  
**You are the Product.**
- **Smart Phone etc**
- **Cookies**
- **GPS**
- **Maps**
- **E mail issues**
- **You are exposed!**



**MY DAD TOLD  
ME YOU'RE  
SPYING ON US**

**HE'S NOT  
YOUR DAD**









Chapter	Section	Description
Chapter 1	Section 1 to 2	Preliminary
Chapter 2	Section 3 to 3A	Digital Signature and Electronic Signature
Chapter 3	Section 4 to 10A	E-Governance
Chapter 4	Section 11 to 13	Attribution Acknowledgement & Distribution of Electronic Records
Chapter 5	Section 14 to 16	Secure Electronic Records & Secure Electronic Signatures
Chapter 6	Section 17 to 34	Regulation of Certifying Authorities
Chapter 7	Section 35 to 39	Electronic Signature Certificates
Chapter 8	Section 40 to 42	Duties of Subscribers
Chapter 9	Section 43 to 47	Penalties, Compensation and Adjudication
Chapter 10	Section 48 to 64	The Cyber Regulations Appellate Tribunal
Chapter 11	Section 65 to 78	Offences
Chapter 12	Section 79	Intermediaries not to be liable in certain cases
Chapter 12A	Section 79A	Examiner of Electronic Evidence
Chapter 13	Section 80 to 90	Miscellaneous

Section	Offence	Description	Penalty
66	Hacking with computer system	If a person with the intent to cause or knowing that he is likely to cause wrongful loss or damage to the public or any person destroys or deletes or alters any information residing in a computer resource or diminishes its value or utility or affects it injuriously by any means, commits hack.	Imprisonment up to three years, or/and with fine up to ₹500,000
66B	Receiving stolen computer or communication device	A person receives or retains a computer resource or communication device which is known to be stolen or the person has reason to believe is stolen.	Imprisonment up to three years, or/and with fine up to ₹100,000
66C	Using password of another person	A person fraudulently uses the password, digital signature or other unique identification of another person.	Imprisonment up to three years, or/and with fine up to ₹100,000

Section	Offence	Description	Penalty
67	Publishing information which is obscene in electronic form.	If a person publishes or transmits or causes to be published in the electronic form, any material which is lascivious or appeals to the prurient interest or if its effect is such as to tend to deprave and corrupt persons who are likely, having regard to all relevant circumstances, to read, see or hear the matter contained or embodied in it.	Imprisonment up to five years, or/and with fine up to ₹1,000,000
67A	Publishing images containing sexual acts	If a person publishes or transmits images containing a sexual explicit act or conduct.	Imprisonment up to seven years, or/and with fine up to ₹1,000,000
67B	Publishing child porn or predated children online	If a person captures, publishes or transmits images of a child in a sexually explicit act or conduct. If a person induces a child into a sexual act. A child is defined as anyone under 18.	Imprisonment up to five years, or/and with fine up to ₹1,000,000 on first conviction. Imprisonment up to seven years, or/and with fine up to ₹1,000,000 on second conviction.
67C	Failure to maintain records	Persons deemed as intermediary (such as an ISP) must maintain required records for stipulated time. Failure is an offence.	Imprisonment up to three years, or/and with fine.

## CYBER LAW IN INDIA

Sl. No	Offences	Section Under IT Act
1	Tampering with computer source Documents	Sec.65
2	Hacking with computer systems, Data Alteration	Sec.66
3	Dishonestly receiving stolen computer resource or communication device	Sec.66B
4	Identity theft	Sec.66C
5	Cheating by personation by using computer resource	Sec.66D
6	Violation of privacy	Sec.66E
7	Cyber terrorism	Sec.66F
8	Publishing or transmitting obscene material in electronic form	Sec .67
9	Publishing or transmitting of material containing sexually explicit act, etc. in electronic form	Sec.67A
10	Punishment for publishing or transmitting of material depicting children in sexually explicit act, etc. in electronic form	Sec.67B
11	Preservation and Retention of information by intermediaries	Sec.67C
12.	Powers to issue directions for interception or monitoring or decryption of any information through any computer resource	Sec.69



13.	Power to issue directions for blocking for public access of any information through any computer resource	Sec.69A
14.	Power to authorize to monitor and collect traffic data or information through any computer resource for Cyber Security	Sec.69B
15.	Un-authorized access to protected system	Sec.70
16.	Penalty for misrepresentation	Sec.71
17.	Breach of confidentiality and privacy	Sec.72
18.	Publishing False digital signature certificates	Sec.73
19.	Publication for fraudulent purpose	Sec.74
20.	Act to apply for offence or contraventions committed outside India	Sec.75
21.	Compensation, penalties or confiscation not to interfere with other punishment	Sec.77
22.	Compounding of Offences	Sec.77A

23.	Offences with three years imprisonment to be cognizable	Sec.77B
24.	Exemption from liability of intermediary in certain cases	Sec.79
25.	Punishment for abetment of offences	Sec.84B
26.	Punishment for attempt to commit offences	Sec.84C
27.	Offences by Companies	Sec.85
	Note : Sec.78 of I.T. Act empowers Police Inspector to investigate cases falling under this Act	
28.	Sending threatening messages by e-mail	Sec .503 IPC
29.	Word, gesture or act intended to insult the modesty of a woman	Sec.509 IPC
30.	Sending defamatory messages by e-mail	Sec .499 IPC
31.	Bogus websites, Cyber Frauds	Sec .420 IPC
32.	E-mail Spoofing	Sec .463 IPC
33.	Making a false document	Sec.464 IPC
34.	Forgery for purpose of cheating	Sec.468 IPC
35.	Forgery for purpose of harming reputation	Sec.469 IPC
36.	Web-Jacking	Sec .383 IPC
37.	E-mail Abuse	Sec .500 IPC
38.	Punishment for criminal intimidation	Sec.506 IPC
39.	Criminal intimidation by an anonymous communication	Sec.507 IPC

40.	When copyright infringed: Copyright in a work shall be deemed to be infringed	Sec.51
41.	Offence of infringement of copyright or other rights conferred by this Act. Any person who knowingly infringes or abets the infringement of	Sec.63
42.	Enhanced penalty on second and subsequent convictions	Sec.63A
43.	Knowing use of infringing copy of computer programme to be an offence	Sec.63B
44.	Obscenity	Sec. 292 IPC
45.	Printing etc. of grossly indecent or scurrilous matter or matter intended for blackmail	Sec.292A IPC
46.	Sale, etc., of obscene objects to young person	Sec .293 IPC
47.	Obscene acts and songs	Sec.294 IPC
48.	Theft of Computer Hardware	Sec. 378
49.	Punishment for theft	Sec.379
50.	Online Sale of Drugs	NDPS Act
51.	Online Sale of Arms	Arms Act

# HOW YOUR PHONE CAN BE HACKED





Text Message  
Sun, 12 Jul, 11:57 AM

Hello, and thank you for reading this letter. You see, there is a starving little boy in Baklaliyatlaglooshen who has no arms, no legs, no parents, and no goats. This little boy's life could be saved, because for every time you pass this on, a rupee will be donated to the Little Starving Legless Armless Goatless Boy from Baklaliyatlaglooshen Fund. Oh, and remember, we have absolutely no way of counting the emails sent and this is all a complete load of junk. So go on reach out. Send this to 5 people in the next 47 seconds. Oh, and a reminder – if you accidentally send this to only 4 or 6 people, you will die instantly!!! Thanks again!!





**DIED**

From not forwarding  
that text message to  
10 people



snopes.com



Apps



YouTube



Maps



News



Search Snopes.com



Support Us

[Submit a Topic](#)

[Shop Snopes](#)

[What's New](#)

[Hot 50](#)

[Fact Checks](#)

[News](#)

[Videos](#)

[Archive](#)

[About Us](#)

[Randomizer](#)

# Did a Starbucks Employee Add the Word "Pig" to a Police Officer's Order?

A Starbucks in Glenpool, Oklahoma, become the center of controversy in late 2019.

[Read More](#)

ADVERTISEMENT

# Are you safe with your e mail Accounts?

**Gmail,yahoo,etc not safe**

**No social media platform is safe**

**.ios/ icloud also not safe!**

**Use privacy settings pl**

**Use your own office/institutions**

**e mail accounts...**



# Which is the safe e mail?

**1.CounterMail**

**2. Protonmail**

**3. Hushmail**

**4. Mailfence**

**5. Tutanota**

**Email encryption**

**Institutions e mails**





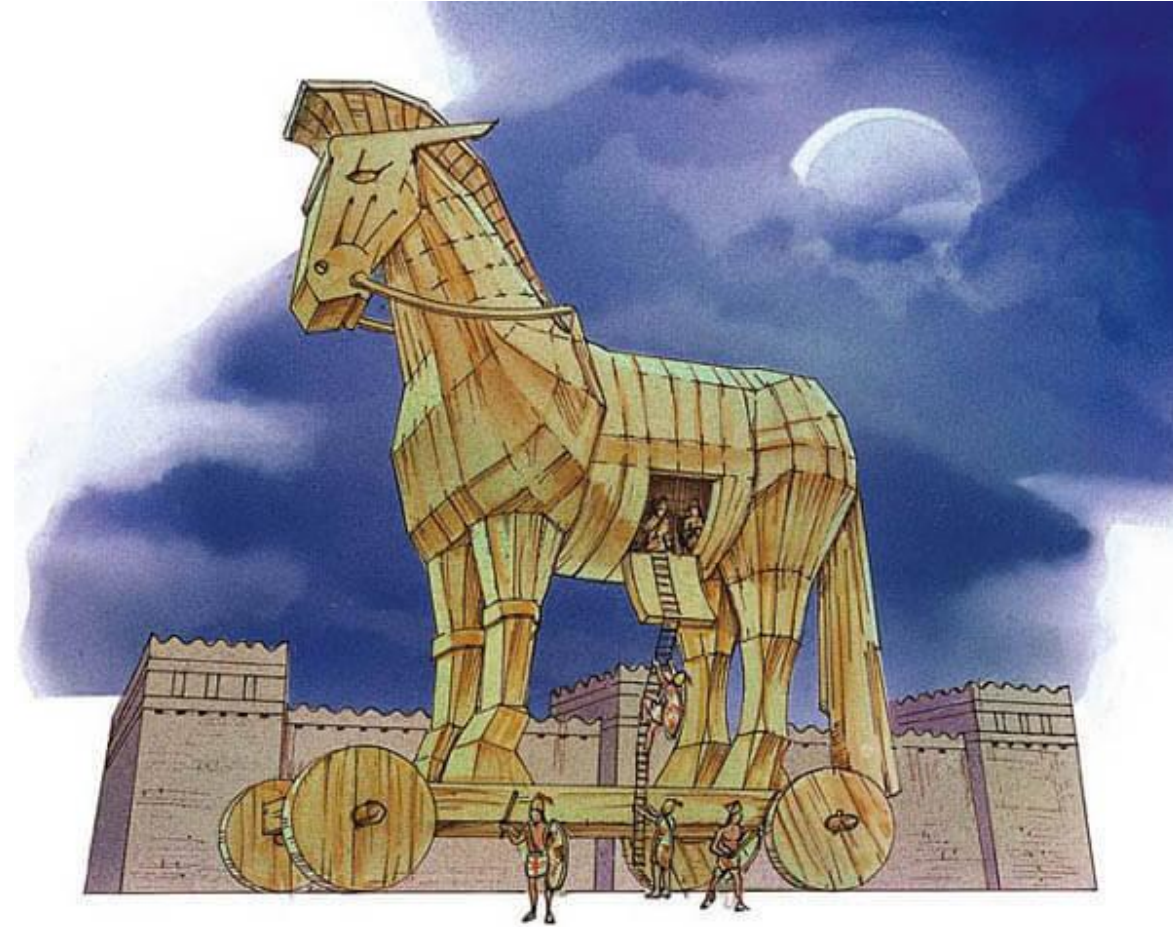







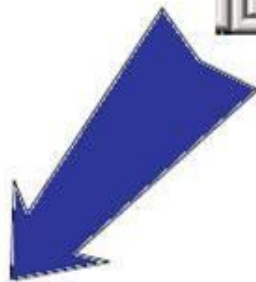

Carrier File



Carrier File with  
Hidden Message

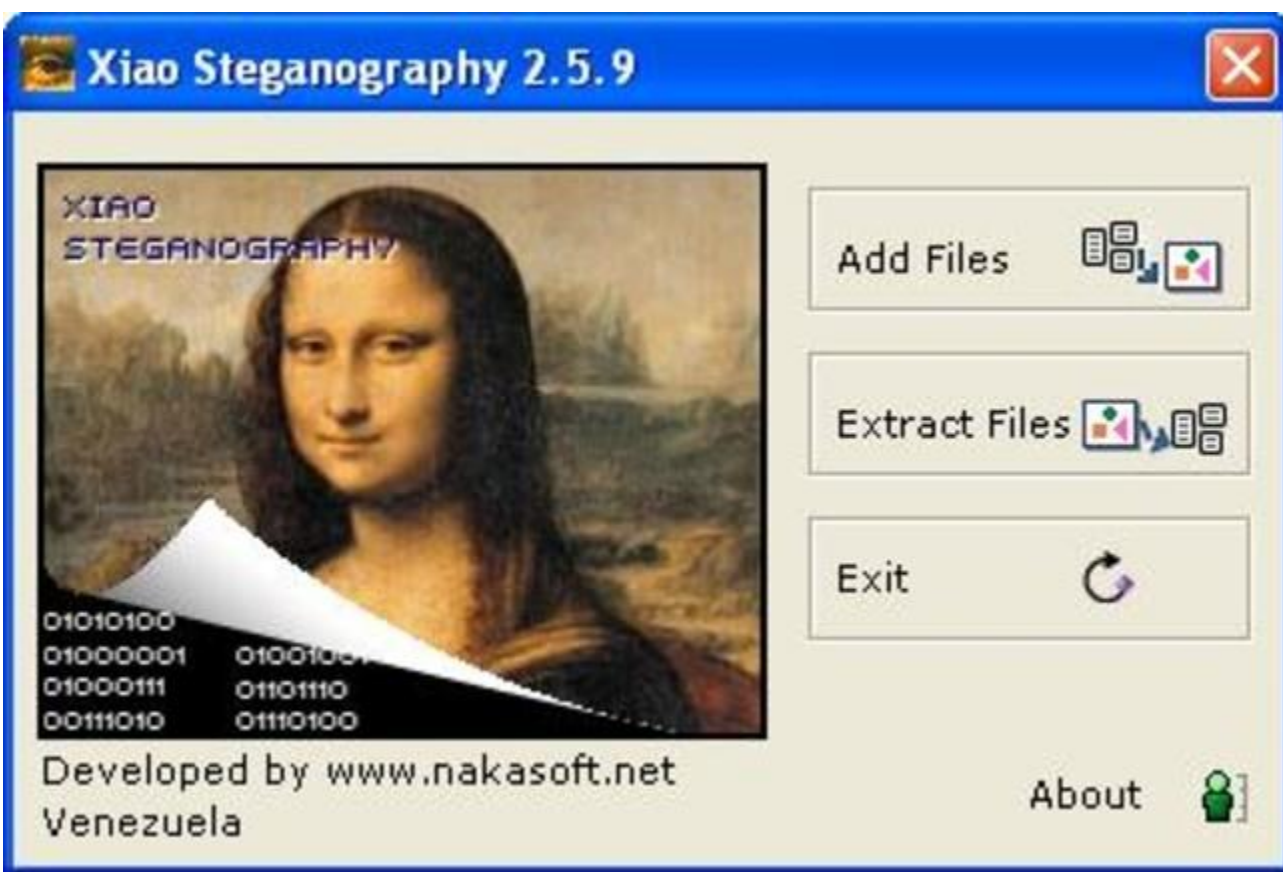

# Nobody is safe, no matter the post

Some of the Indians whose phone numbers figured on the leaked list of potential surveillance targets, according to The Wire, The Guardian and 14 other media outlets that formed a collective for the Pegasus Project



Rahul Gandhi's number and that of his advisors and friends was on the list before 2016 elections

Ashok Lavasa became election commissioner in January 2016 and resigned in August 2016

Supreme Court lawyer Prashant Mishra was accused from CJI Dipankar Ghose's witness harassment

Hitesh Mishra, later named an accused in the Kanpur Panchayat case, was on the list in 2017

Gangadhar Karmakar, who was in 2016 helping with the Niyam response

Prashant Kishor, political strategist who helped Lavasa and Trivedi's Bengal election

Abhishek Banerjee, nephew of Manmohan Singh, was on the list in 2016

Sachin Sinha, close associate of Rahul Gandhi, was on the list in 2016

Abhishek Sinha, member of close associate of Rahul Gandhi, was on the list in 2016

Arjun Singh, a member of the Union Minister's office

Arvind Kejriwal, appointed IT minister in the Modi cabinet, was on the list in 2017

Prakash Singh Patel, Union minister, his family and staff were on the list in 2017

M. Hanumanth, Director of the Hill and Marine Corps, was on the list in 2017

Sudhakar Singh, journalist who investigated the Madia case

Sudhakar Varadachari, founding editor of 'The Wire'

M. S. Venk, founding editor of 'The Wire'

Rishabh Singh, journalist who investigated into the finances of Amit Shah's son Jay Shah

Swati Chatterjee, journalist and author of 'From a prof', a book on the BJP's digital army

## Use of data not spying: Minister

**NEW DELHI** New information technology minister Ashok Lavasa said on Tuesday that use of data for surveillance is not spying, but a legitimate use of data. He said that the government is not spying on citizens, but is using data for surveillance. Lavasa said that the government is using data for surveillance, but it is not spying. He said that the government is using data for surveillance, but it is not spying. He said that the government is using data for surveillance, but it is not spying.

## Shah goes back to 'chronology'

**OUR SPECIAL CORRESPONDENT**  
**New Delhi** Union home minister Amit Shah has returned to the chronology of the alleged phone tapping of prominent opposition leaders in the country since last year, after the country's leading legal experts on Monday slammed the timing of the leak and demanded the lifting of the ban on the release of the data. Shah said that the government is using data for surveillance, but it is not spying. He said that the government is using data for surveillance, but it is not spying.



Amit Shah

## Congress seeks probe on PM

**FROM PAGE 1**  
The Congress today demanded that the government should conduct a probe into the alleged phone tapping of prominent opposition leaders in the country since last year. The party also demanded that the government should conduct a probe into the alleged phone tapping of prominent opposition leaders in the country since last year. The party also demanded that the government should conduct a probe into the alleged phone tapping of prominent opposition leaders in the country since last year.

## Don't treat computer content as proof: Hany's wife

**FROM PAGE 2**  
Among the surveillance targets named by the spyware are prominent opposition leaders in the country since last year. The party also demanded that the government should conduct a probe into the alleged phone tapping of prominent opposition leaders in the country since last year. The party also demanded that the government should conduct a probe into the alleged phone tapping of prominent opposition leaders in the country since last year.

## Bengal polls were not spared either

**FROM PAGE 2**  
The Wire, Amnesty's forensic analysis found traces of infection on Rahul's phone on April 20, just a day before the start of the Bengal polls. The Wire, Amnesty's forensic analysis found traces of infection on Rahul's phone on April 20, just a day before the start of the Bengal polls. The Wire, Amnesty's forensic analysis found traces of infection on Rahul's phone on April 20, just a day before the start of the Bengal polls.

...and that of his advisors and friends was on the list before 2016 elections

...and that of his advisors and friends was on the list before 2016 elections

...and that of his advisors and friends was on the list before 2016 elections

...and that of his advisors and friends was on the list before 2016 elections

...and that of his advisors and friends was on the list before 2016 elections

...and that of his advisors and friends was on the list before 2016 elections

...and that of his advisors and friends was on the list before 2016 elections

...and that of his advisors and friends was on the list before 2016 elections

...and that of his advisors and friends was on the list before 2016 elections

...and that of his advisors and friends was on the list before 2016 elections



# SUPERSPY

The Pegasus spyware, developed by Israeli cyberarms firm NSO Group, can infiltrate Android devices and certain versions of Apple's iOS. Here is how it works

Transmitted by a WhatsApp call to the target phone. Enters even if the call is not answered

It does not transmit data when a smartphone is roaming, unless it is on WiFi. This is to avoid the scrutiny that may follow high data charges

- Designed to never use more than 5% of the space on the phone
- When unable to transmit, it collects and stores data in an encrypted buffer
- Removes data on a first-in first-out basis if it has not been able to transmit for a while

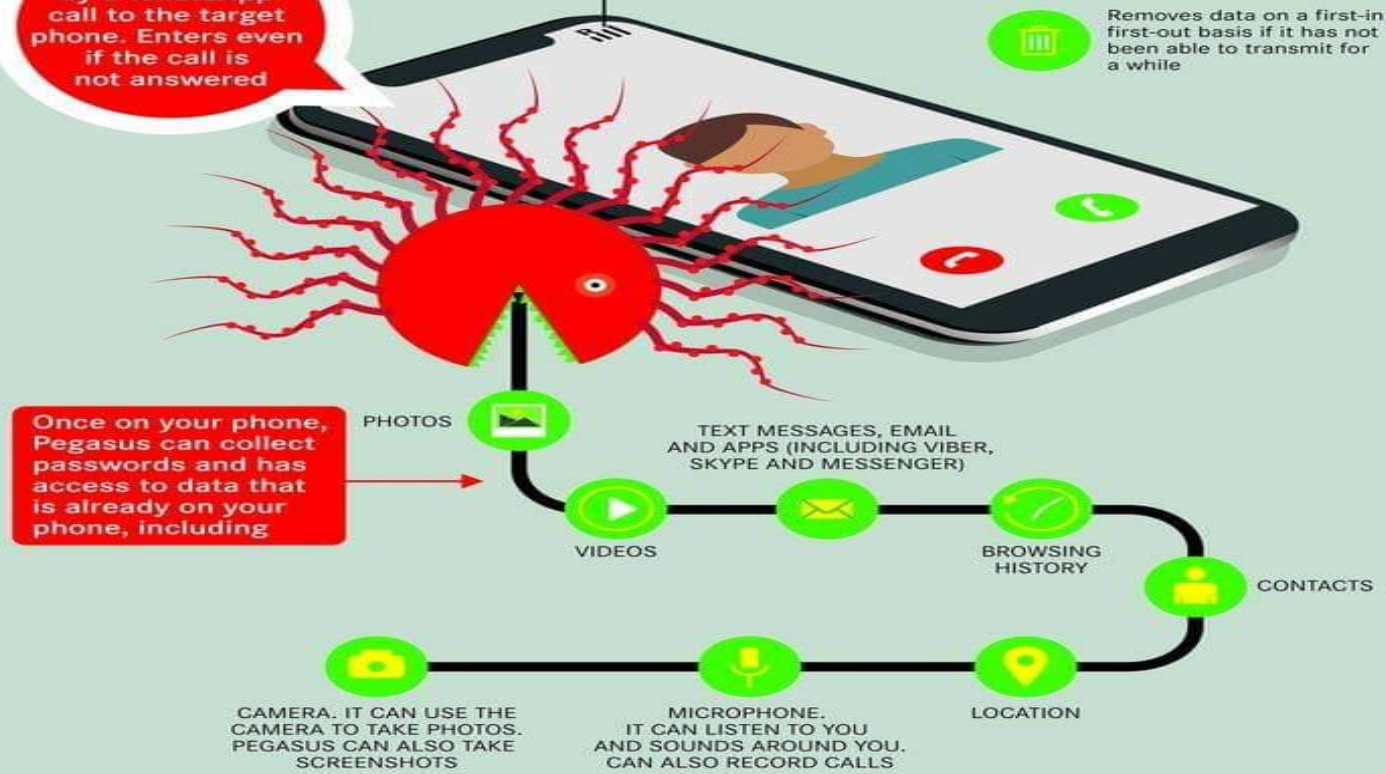

RESEARCH: PRADIP R. SAGAR  
SOURCE: PRASHANT MALI, CYBER LAW AND CYBER SECURITY EXPERT

GRAPHICS: SREEMANIKANDAN S.





# How Pegasus works?

- **end-to-end encryption became commonplace as messaging moved onto encrypted email and apps like WhatsApp and Signal.**
- **Governments unable to listen in — and desperate for a solution.**
- **To meet that need, Pegasus was born.**

## What is Pegasus?

Pegasus is the hacking software – or spyware – that is developed, marketed and licensed to governments around the world by the Israeli company NSO Group. It has the capability to infect billions of phones running either iOS or Android operating systems.

First it was discovered in 2016; it infected the phones through a method called spear-phishing – text messages or emails that trick a target into clicking on a malicious link.

Now after the previous hacks what Pegasus has done the method is known to people and agencies;

A new method came up called “Zero-Click”

which do not require any interaction from the phone’s owner in order to succeed.

- In 2019 WhatsApp revealed that NSO’s software had been used to send malware to more than 1,400 phones by exploiting a zero-click vulnerability. Simply by placing a WhatsApp call to a target device, malicious Pegasus code could be installed on the phone, even if the target never answered the call.
- More recently NSO has begun exploiting vulnerabilities in Apple’s iMessage software, giving it backdoor access to hundreds of millions of iPhones. Apple says it is continually updating its software to prevent such attacks.
- Where neither spear-phishing nor zero-click attacks succeed, Pegasus can also be installed over a wireless transceiver located near a target, or, according to an NSO brochure, simply manually installed if an agent can steal the target’s phone.
- NSO main is also to make sure to find a bug in your phone; security researchers and hackers spend a lot of time and effort to uncover these bugs. One with the intention of reporting/fixing them, while the other with the intent of using them to “hack” your phones.

# NSO

- **The NSO Group is a private company based in Israel that is a leading maker of spyware.**
- **Its signature product, Pegasus, is designed to break into iPhones and Android devices.**
- **Founded in 2010, the company says it has 60 government customers in 40 countries.**
- **The company, which also has offices in Bulgaria and Cyprus, reportedly has 750 employees and recorded revenue of more than \$240 million last year,**



# Pegasus...

- NSO Group claims that its Pegasus spyware is only used to “investigate terrorism and crime” and “leaves no traces whatsoever”.
- This Forensic Methodology Report shows that neither of these statements are true.

# WHAT DO YOUR DEVICES KNOW ABOUT YOU?

Whether it's a computer on your desk or a phone in your pocket, your devices retain a lot of personal data. And all of that information may be vulnerable to cybercriminals.



## Passwords

- Windows, Apple, Android, Smartphone icons
- Web browser autofill
- Stored in the file System

## Credit Card Numbers

- Windows, Apple, Android, Smartphone icons
- Web browser autofill
- Downloaded credit card statements

## Social Security Number

- Windows, Apple, Android, Smartphone icons
- Aadhar Number
- Downloaded Tax documents

## Deleted Files

- Windows, Apple, Android, Smartphone icons
- All deleted files, including ones no longer in recycle bin or trash, can be recovered until physical storage space overwritten.

## Text Messages

- Smartphone icon
- Text log stored on phone

## Bank Account Info

- Windows, Apple, Android, Smartphone icons
- Downloaded bank statements

## Phone Calls

- Smartphone icon
- Call log Stored on phone

## Recent Files

- Windows, Apple, Android, Smartphone icons
- Various applications keep their own recent file lists
- List kept by operating system

## Recently Visited Sites, Viewed area, Used app, Searched for

- Windows, Apple, Android, Smartphone icons
- Browser's cache
- Browser's history
- Cookies

## Current Locations

- Android, Smartphone icons
- Readable off your GPS

Knowing what information your device contains is the first step to protection

## Name and Address

- Windows, Apple, Android, Smartphone icons
- Web browser autofill
- Windows Contacts
- Address Book
- Contact manager

## Contacts

- Windows, Apple, Android, Smartphone icons
- Windows Contacts
- Address Book
- Contact manager

## Recent Locations

- Android, Smartphone icons
- Recent Photos in Cyber Crime!
- Navigation apps

## Biometric Info

- Windows, Apple, Android, Smartphone icons
- Unique identifiers include fingerprints, retina and iris patterns, voice waves.
- Spy CAM & Micro Phones

Solution!







# TELEPHONE BOOTH

EARLIER                      NOW



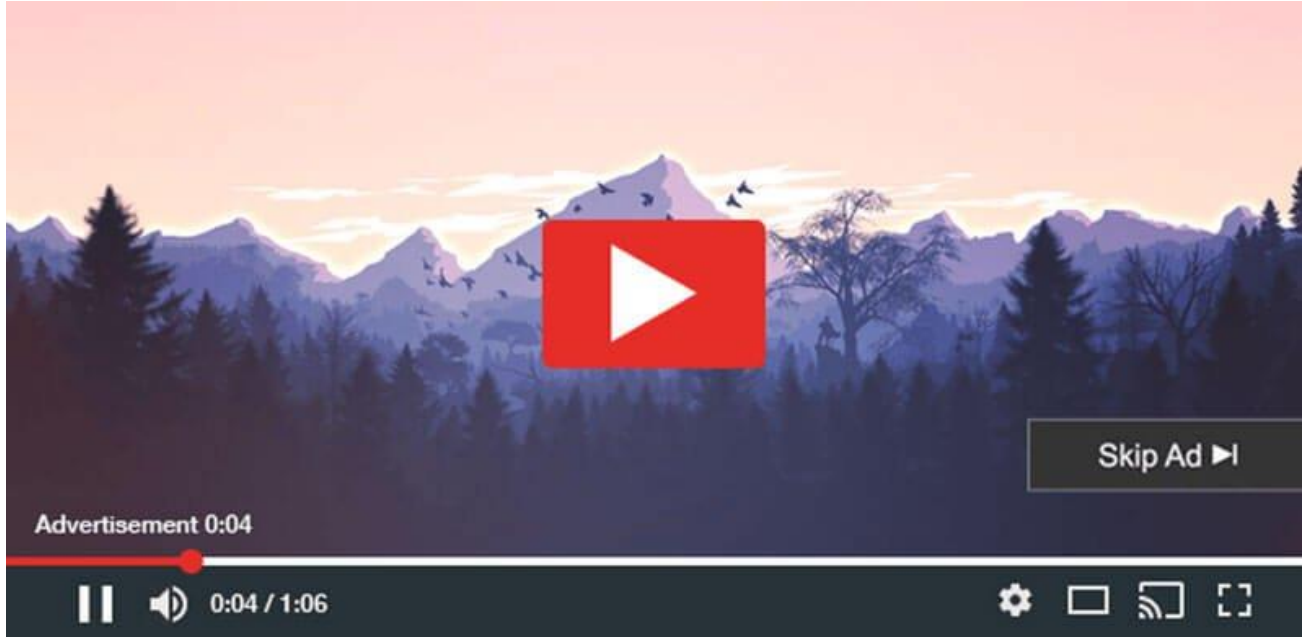

Advertisement 0:04

Skip Ad ▶

0:04 / 1:06

# How This 7-Year-Old Made \$22 Million Playing With Toys



**Madeline Berg** Forbes Staff

Media

*Following the money*







## Pornhub's Top 20 Countries



Proportion of Worldwide Traffic

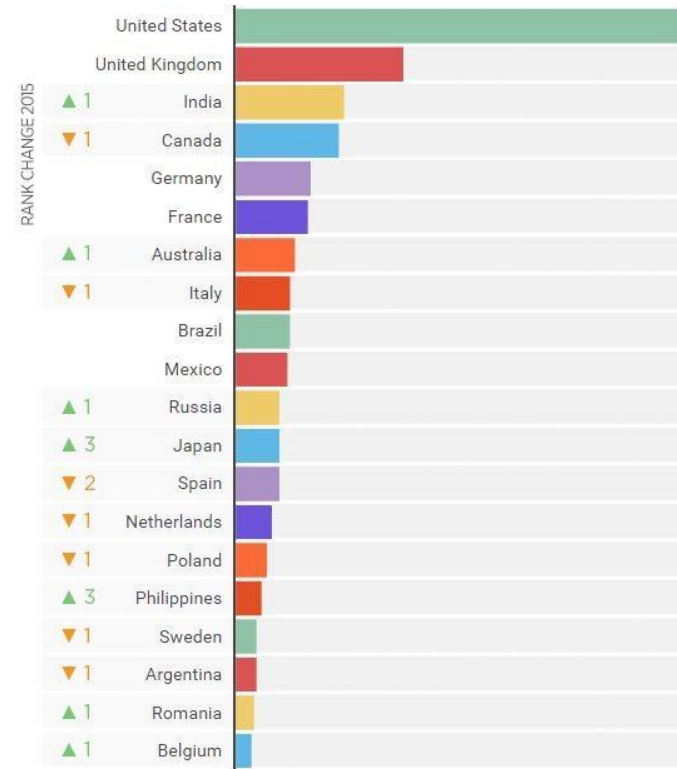

## Hourly Traffic Worldwide

Pornhub

Favorite Times to Watch Porn (weekly average)

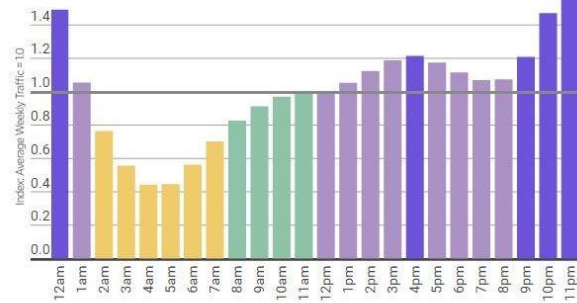

Percent Change in Traffic by Day (compared to weekly average)

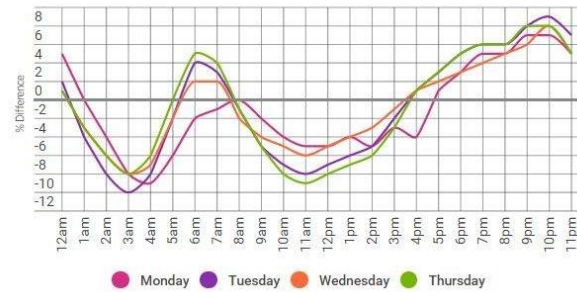
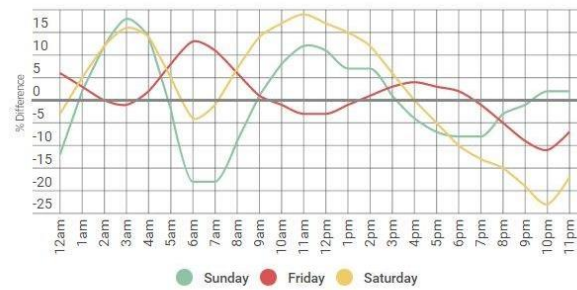







HOW MANY WORDS IN ENGLISH  
LANGUAGE?





Hi, how can I help?

## How many words in the English language?

- **171,476 words (approximately)**
- **The Second Edition of the 20-volume Oxford English Dictionary contains full entries for 171,476 words in current use,**



Which?

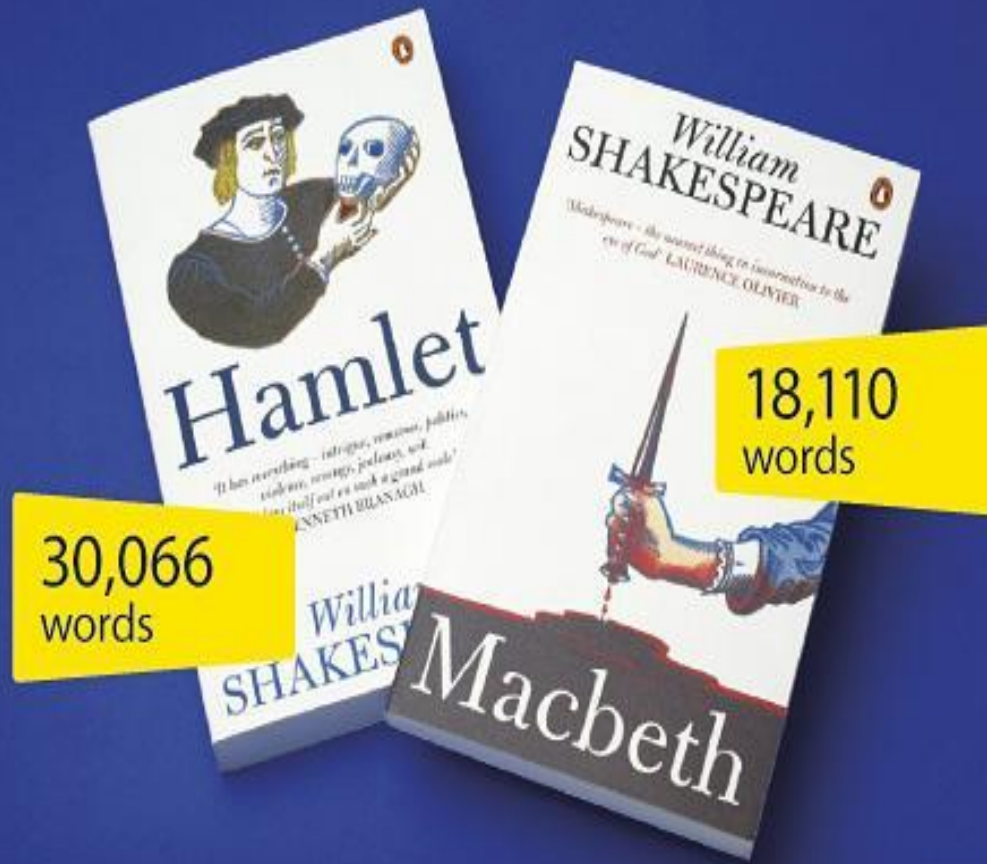

WEBSITE/SERVICE/BOOK	TOTAL WORDS*
PAYPAL	36,275
HAMLET	30,066
APPLE ITUNES	19,972
MACBETH	18,110
WINDOWS LIVE	14,714
APPLE iOS 5	13,366
FACEBOOK	11,195
GOOGLE ALL-INCLUSIVE	10,640
APPLE iCloud	10,724
AMAZON KINDLE	7,115
AMAZON.CO.UK	5,212
TWITTER	4,445
GOOGLE	4,099

# “I agree to terms” checkbox

## Terms of Service Update

A change in our [Terms of Service](#) takes effect on February 12, 2014. Please read them carefully. A high-level summary of the changes is available [here](#).

I accept the new Terms of Service.

Continue

Decline

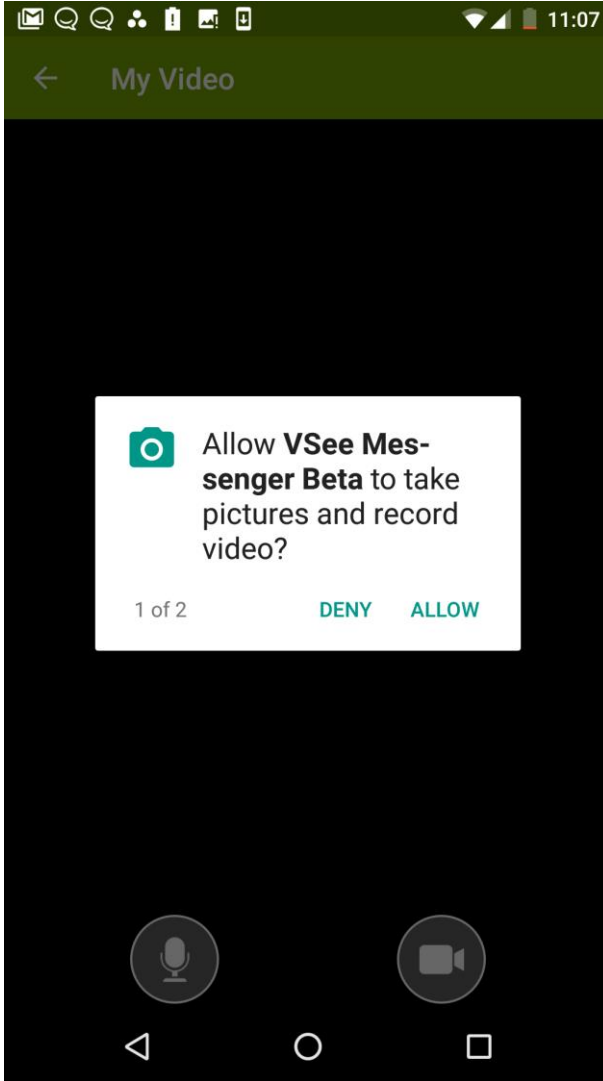

11:07

← My Video

 Allow **VSee Messenger Beta** to take pictures and record video?  
1 of 2      DENY    ALLOW

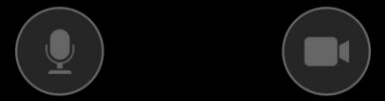

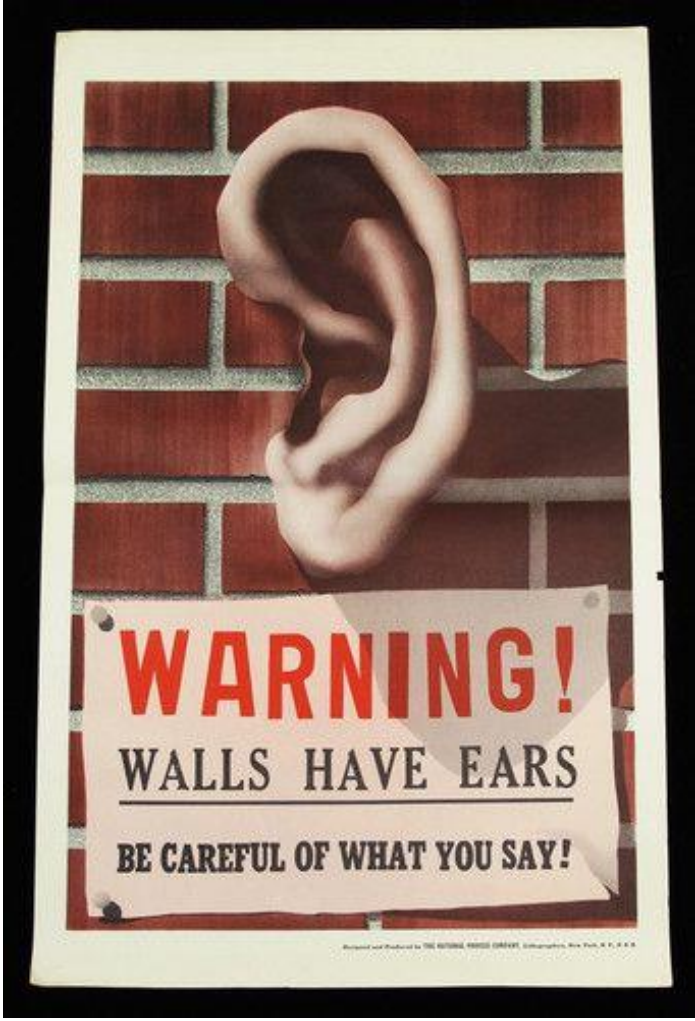

**WARNING!**

**WALLS HAVE EARS**

**BE CAREFUL OF WHAT YOU SAY!**

Produced and Published by THE NATIONAL BUREAU OF FIRE PREVENTION, Washington, D. C., U. S. A.





# Edmond Locard's (Sherlock Holmes of France) Principle

Every contact by a criminal  
leaves behind a trace.





Action	Time	Description	Filename	Full Path	More Information	File Ext...
	31/05/2018 09:41:58	Run .EXE file	rundll32.exe	C:\Windows\System32\rundll...	Microsoft Corporation, Microso...	exe
	31/05/2018 09:41:57	Wireless Network Disconnected				
	31/05/2018 09:41:55	Resumed from sleep				
	20/05/2018 11:53:09	Sleep				
	20/05/2018 11:53:08	Task Run	rundll32.exe	C:\WINDOWS\system32\rund...	Pre-staged app cleanup, \Micro...	exe
	20/05/2018 11:53:04	Run .EXE file	DWM.EXE	C:\WINDOWS\SYSTEM32\DW...	Microsoft Corporation, Microso...	EXE
	20/05/2018 11:10:07	Run .EXE file	mscorsvw.exe	C:\Windows\MICROSOFT.NE...	Microsoft Corporation, Microso...	exe
	20/05/2018 10:45:30	Run .EXE file	WINWORD.EXE	C:\PROGRAM FILES\MICROS...	Microsoft Corporation, Microso...	EXE
	20/05/2018 10:45:23	Run .EXE file	rundll32.exe	C:\Windows\System32\rundll...	Microsoft Corporation, Microso...	exe
	20/05/2018 10:45:11	Run .EXE file	chrome.exe	C:\PROGRAM FILES (X86)\Go...	Google Inc., Google Chrome, G...	exe
	20/05/2018 10:31:01	Run .EXE file	dllhost.exe	C:\Windows\System32\dllhos...	Microsoft Corporation, Microso...	exe
	20/05/2018 10:30:16	Run .EXE file	svchost.exe	C:\Windows\System32\svcho...	Microsoft Corporation, Microso...	exe
	20/05/2018 10:23:52	Run .EXE file	WmiPrivSE.exe	C:\Windows\SysWOW64\wbe...	Microsoft Corporation, Microso...	exe
	20/05/2018 10:23:33	Run .EXE file	AVIRA.SYSTRAYSTARTTR...	C:\PROGRAM FILES (X86)\Avir...	Avira Operations GmbH & Co. K...	EXE
	20/05/2018 10:23:15	Run .EXE file	SnagPriv.exe	C:\PROGRAM FILES\TECHSMI...	TechSmith Corporation, SnagPri...	exe
	20/05/2018 10:14:10	Run .EXE file	dllhost.exe	C:\Windows\System32\dllhos...	Microsoft Corporation, Microso...	exe
	20/05/2018 10:14:09	Run .EXE file	svchost.exe	C:\Windows\System32\svcho...	Microsoft Corporation, Microso...	exe
	20/05/2018 10:14:05	Task Run	TpmTasks.dll	C:\WINDOWS\system32\Tpm...	Secure-Boot-Update, \Microsoft...	dll
	20/05/2018 10:14:05	Task Run	sppcext.dll	C:\WINDOWS\System32\sppc...	SvcRestartTaskLogon, \Microsof...	dll
	20/05/2018 10:14:00	Run .EXE file	SearchUI.exe	C:\Windows\SYSTEMAPPS\M...	Microsoft Corporation, Microso...	exe
	20/05/2018 10:14:00	Run .EXE file	WWAHost.exe	C:\Windows\System32\WWA...	Microsoft Corporation, Microso...	exe
	20/05/2018 10:14:00	Run .EXE file	SHELLEXPERIENCEHOST...	C:\Windows\SYSTEMAPPS\S...	Microsoft Corporation, Microso...	EXE
	20/05/2018 10:11:33	Wireless Network Connected				
	20/05/2018 10:11:09	View Folder in Explorer	Service Packs	Downloads\Microsoft\Service...		
	20/05/2018 10:11:09	View Folder in Explorer	Forensics	Forensics		

1326 item(s), 1 Selected

MirSoft Freeware. <http://www.nirsoft.net>



Computer Name	Friendly Name	Serial No	Mount Point 2	Drive Letter	Usb Stor Date Time
NOTEBOOK	Patriot Memory USB Device	07AC0F0137F...	[Andrew:27/07/2014 ...		26/05/2015 06:49:46
NOTEBOOK	Patriot Memory USB Device	07B31101655...	[Andrew:15/11/2014 ...		26/05/2015 06:49:46
NOTEBOOK	Apple iPod USB Device	000A2700102...	[Andrew:21/09/2014 ...	F:	26/05/2015 06:49:46
NOTEBOOK	GENERIC USB Mass Stor...	7&1bdfb34c&0	[Andrew:06/06/2015 ...		06/06/2015 21:19:55
NOTEBOOK	Kingston DataTraveler 2.0 ...	C8600088635...	[Andrew:06/06/2015 ...	E:	06/06/2015 21:20:19
NOTEBOOK	Samsung M3 Portable US...	00000000011...			23/06/2015 17:17:10
NOTEBOOK	SanDisk Cruzer USB Devi...	20042103310...	[Andrew:07/10/2014 ...		26/05/2015 06:49:46
NOTEBOOK	SanDisk Cruzer USB Devi...	20054963900...	[Andrew:14/09/2014 ...		26/05/2015 06:49:46
NOTEBOOK	SanDisk Cruzer USB Devi...	20060876910...	[Andrew:22/05/2014 ...		26/05/2015 06:49:46
NOTEBOOK	SanDisk Cruzer USB Devi...	25851105081...	[Andrew:22/05/2014 ...		26/05/2015 06:49:46
NOTEBOOK	SanDisk U3 Cruzer Micro ...	0000185E257...	[Andrew:13/04/2014 ...		26/05/2015 06:49:46
NOTEBOOK	SMI USB DISK USB Device	20101016000...	[Andrew:07/09/2014 ...		26/05/2015 06:49:46
NOTEBOOK	WD Ext HDD 1021 USB D...	57434156354...			23/06/2015 17:17:10



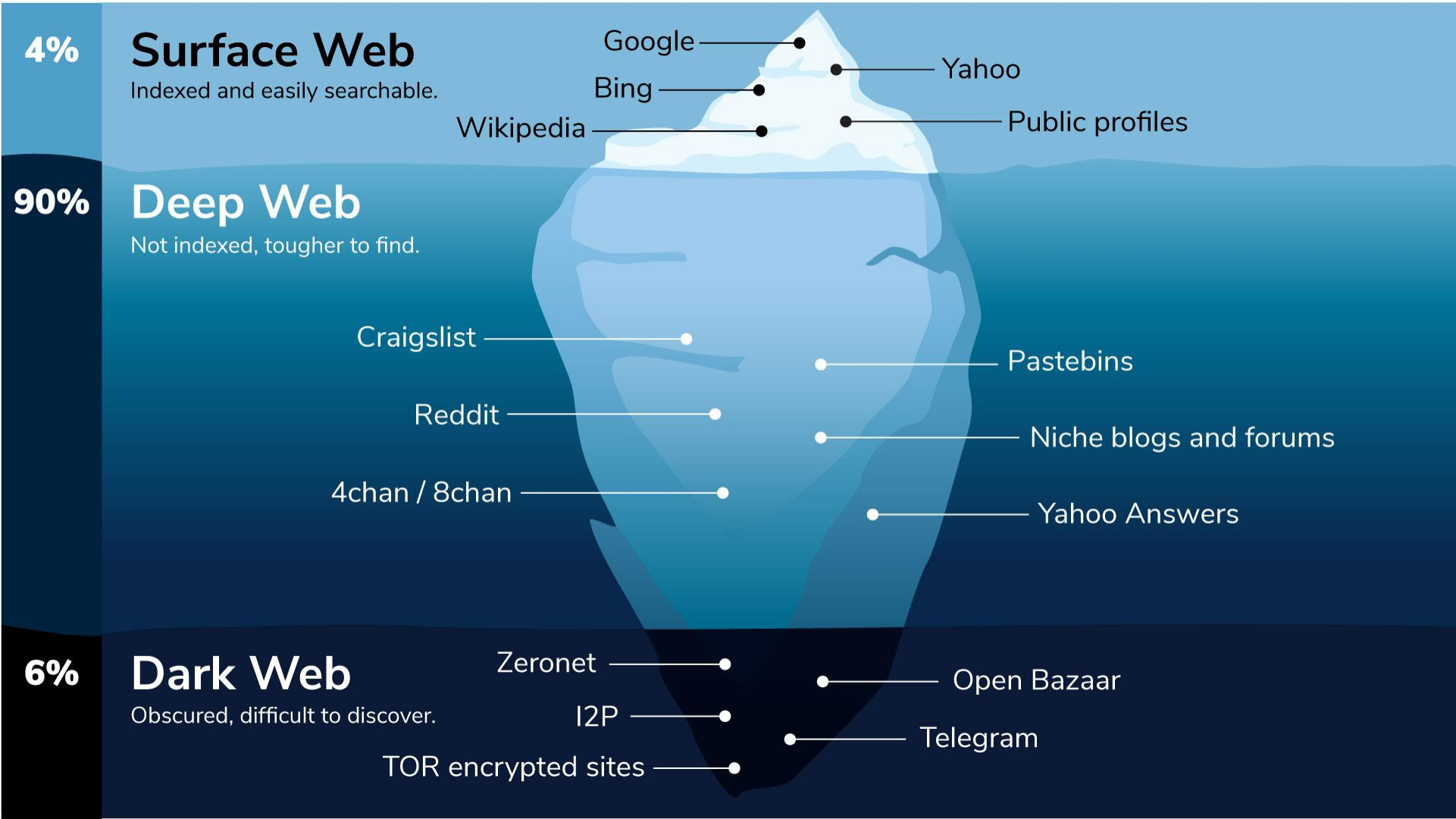

4%

## Surface Web

Indexed and easily searchable.

- Google
- Bing
- Wikipedia
- Yahoo
- Public profiles

90%

## Deep Web

Not indexed, tougher to find.

- Craigslist
- Reddit
- 4chan / 8chan
- Pastebins
- Niche blogs and forums
- Yahoo Answers

6%

## Dark Web

Obscured, difficult to discover.

- Zeronet
- I2P
- TOR encrypted sites
- Open Bazaar
- Telegram

# Joffrey Bruin

- He cycles
- He is from Netherlands



## What a sports app tells us

1. Joffrey Bruin
1. Heiloo, Netherlands
2. Weekly Bicycle ride
2. 17 march 2015 = Tuesday
2. Duration ride 1:25:57
3. Map of the Route

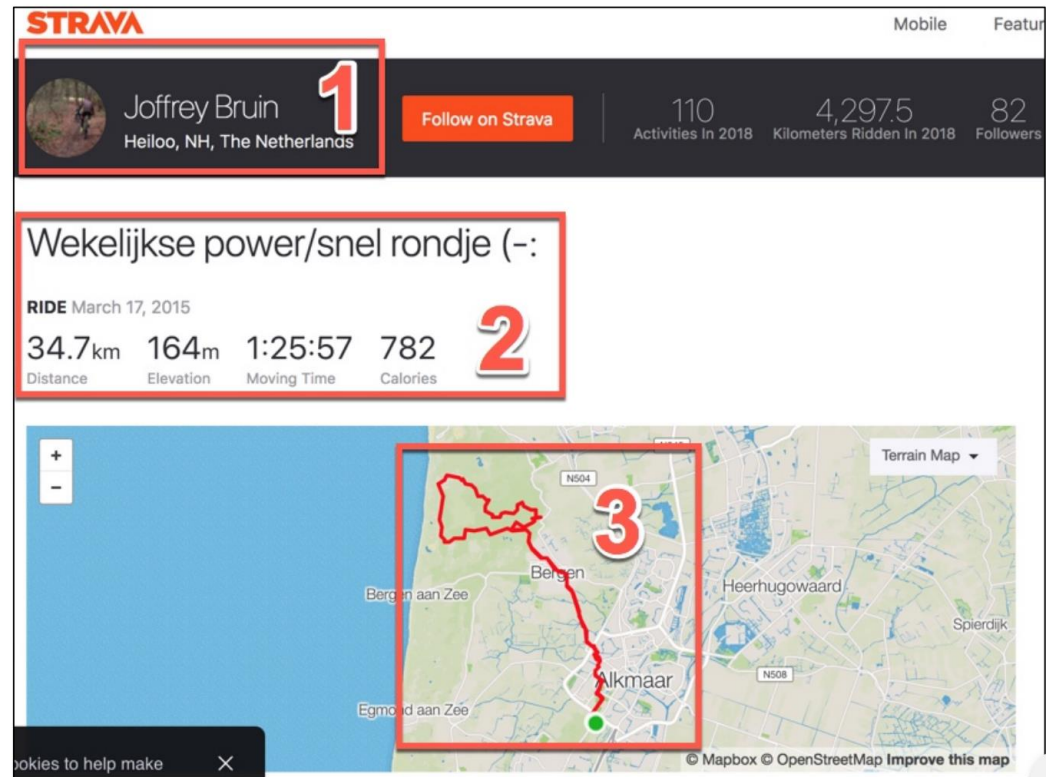

# Twitter



**Joffrey Bruin**  
@joffrey1981

Nu al weer zin in de volgende marathon!!!!

alkmaar

[deflexwinkel.nl/mtbteam](http://deflexwinkel.nl/mtbteam)

Joined November 2010

Photos and videos

Tweets	Following	Followers	Likes
665	173	100	4

**Tweets** Tweets & replies Media

Joffrey Bruin Retweeted  
**Duchenne Heroes** @Duchenne\_Heroes · 24 Feb 2013  
Het lijkt erop dat we blijven hangen op 394 deelnemers.. NEE TOCH!?!? Doe mee met #duchenne\_heroes! Op naar minimaal 400 deelnemers! PL RT

Joffrey Bruin Retweeted  
**Jeroen van Melsen** @Jeroenvanmelsen · 2 Feb 2013  
Morgen laatste voorbereiding examen WFT Pensioen, daarna focus op fietsen en Duchenne Heroes! Nieuwsgierig? Check [deflexwinkel.nl/mtbteam/](http://deflexwinkel.nl/mtbteam/)

Joffrey Bruin Retweeted  
**IJsclub Koedijk** @IJsclubKoedijk · 16 Jan 2013  
Met dank aan @gijlsleijen: Op het meertje aan de Achtergraft (achter Kanaaldijk 40) kan al geschaatst worden. Wees a.u.b. zuinig op het ijs!

**Joffrey Bruin**  
@joffrey1981

Trots op haar nieuwe skeelers die ze heeft gehad voor haar vijfde verjaardag!



3:24 AM - 9 Jun 2012

**Joffrey Bruin**  
@joffrey1981

@mjthvanleeuwen ja het was zwaar en zeer stoffig de #5vs



8:27 AM - 7 Apr 2012

# Yellow Pages & Streetview



telefoonboek.nl

Bedrijf zoeken Persoon zoeken Goo

Wie zoekt u? (bijv. "Janssen") Waar? (bijv. "Amsterdam")

J Bruin Heiloo

U bent hier: Telefoonboek > Personen > Bruin heiloo > J bruin heiloo

**J Bruin**  
Kennemerstraatweg 37  
1851AT  
Heiloo



# LinkedIn

- Past en Current jobs
- Education
- Validation on previous results



**Joffrey Bruin**  
Solution Architect at Basware  
Amsterdam Area, Netherlands  
Information Technology and Services

500+ connections

Current Basware  
Previous Konica Minolta Business Solutions Nederland BV, De Flexwinkel B.V., Dantuma BV  
Education Comptia  
Recommendations 4 people have recommended **Joffrey Bruin**



**Business Process Consultant**  
Konica Minolta Business Solutions Nederland BV  
June 2013 – July 2016 • 3 years 2 months  
Nederland



**Business Consultant Strategic Accounts**  
Konica Minolta Business Solutions Nederland BV  
September 2013 – April 2015 • 1 year 8 months  
Amsterdam



**Regiomanager Alkmaar e.o.**  
De Flexwinkel B.V.  
September 2012 – June 2013 • 10 months  
Alkmaar Area, Netherlands



**Senior Business Consultant document solutions**  
Dantuma BV  
May 2009 – September 2012 • 3 years 5 months  
Haarlem Area, Netherlands

# Facebook

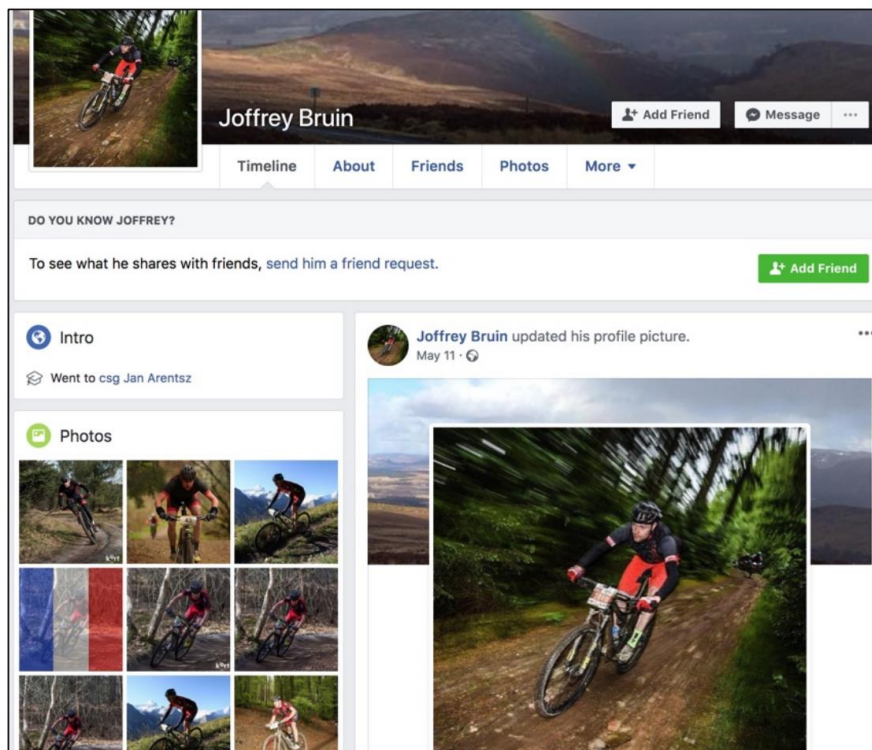

**Joffrey Bruin** Add Friend Message ...

Timeline About Friends Photos More ▾

DO YOU KNOW JOFFREY?

To see what he shares with friends, send him a friend request. Add Friend

**Intro**  
Went to csg Jan Arentsz

**Photos**

Joffrey Bruin updated his profile picture. May 11 · 🌐

Profile picture: A cyclist riding on a dirt trail through a forest.

### About

To see what he shares with friends, send him a friend request. Add Friend

#### Overview

- Work and Education: No workplaces to show
- Places He's Lived: Went to csg Jan Arentsz
- Family and Relationships: Lives in Heiloo From Alkmaar
- Details About Joffrey
- Life Events: No relationship info to show



# Facebook

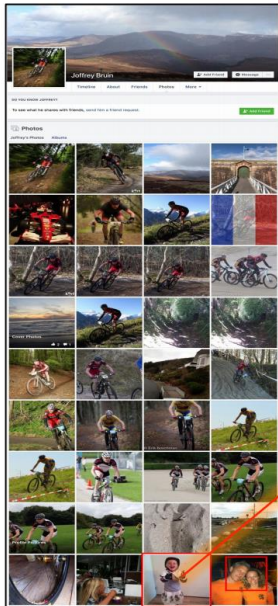





## Pic2Map Photo Location Viewer

Can't remember the location where you took a picture with your camera or smartphone? Upload your photos and find out where they were taken. Pic2Map analyzes EXIF data embedded in the image to find the GPS coordinates and location. The result would be a map view of your photo with detailed address and additional EXIF information if available.

**Drag and drop your images here to upload**

or



Select Photo Files



Make the photos public? ⓘ



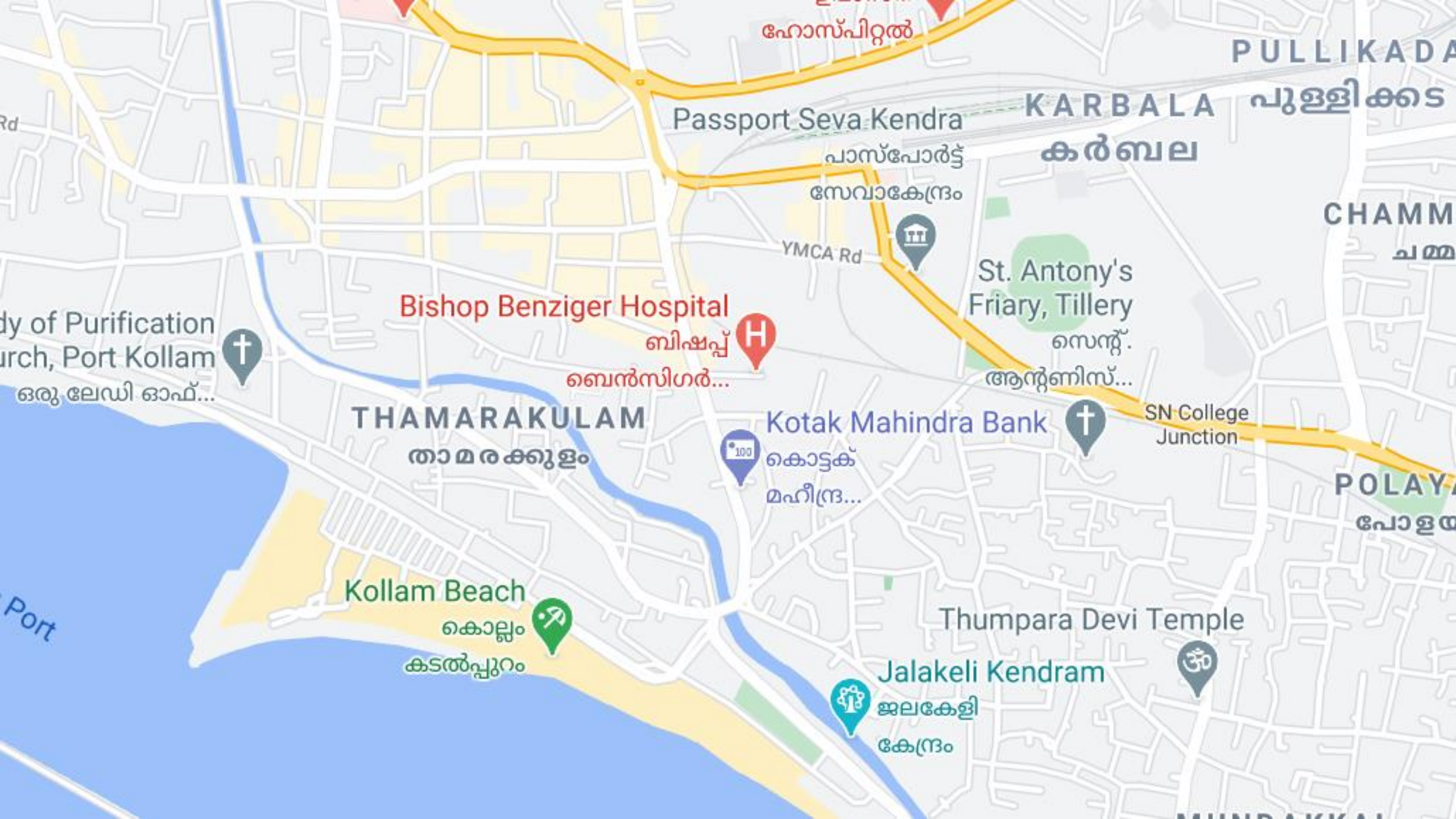

ഹോസ്പിറ്റൽ

PULLIKADA

പുള്ളിക്കട

Passport Seva Kendra

KARBALA

കർബല

പാസ്പോർട്ട് സേവാകേന്ദ്രം

YMCA Rd

St. Antony's Friary, Tillery

സെന്റ്. ആന്റണിസ്...

Bishop Benziger Hospital

ബിഷപ്പ് ബെൻസിഗർ...

Church of Purification, Port Kollam

ഒരു ലേഡി ഓഫ്...

THAMARAKULAM

താമരക്കുളം

Kotak Mahindra Bank

കൊട്ടക് മഹീന്ദ്ര...

SN College Junction

POLAYA

പോളയ

Kollam Beach

കൊല്ലം കടൽപ്പുറം

Thumpara Devi Temple

Jalakeli Kendram

ജലകേളി കേന്ദ്രം

Port

MUNDAKKAL

EXIF Tag	Value
Filename	IMG_1861.CR2
ImageWidth	320931328
ImageLength	1024
BitsPerSample	8 8 8
Compression	6 (JPG)
Make	Canon
Model	Canon EOS 20D
StripOffset	9728
Orientation	Top left
StripByteCount	375994
XResolution	72
YResolution	72
ResolutionUnit	Inch
Date Time	2016:08:06 10:30:41
ExifOffset	270
ExposureTime	1/400 seconds
FNumber	5.60
ExposureProgram	Shutter priority
ISOSpeedRatings	100
ExifVersion	0221
Date Time Original	2016:08:06 10:30:41
Date Time Digitized	2016:08:06 10:30:41
ComponentsConfiguration	
ShutterSpeedValue	1/400 seconds
ApertureValue	F 5.60
ExposureBiasValue	-0.33
MeteringMode	Multi-segment
Flash	Flash not fired, compulsory flash mode





# ';--have i been pwned?

Check if you have an account that has been compromised in a data breach

email address

pwned?

# FACEBOOK AI ENGINE









# HOW DO

# HACKERS

# HACK?





## PRINCIPLE 1

# THE HUMAN BRAIN IS NOT A COMPUTER

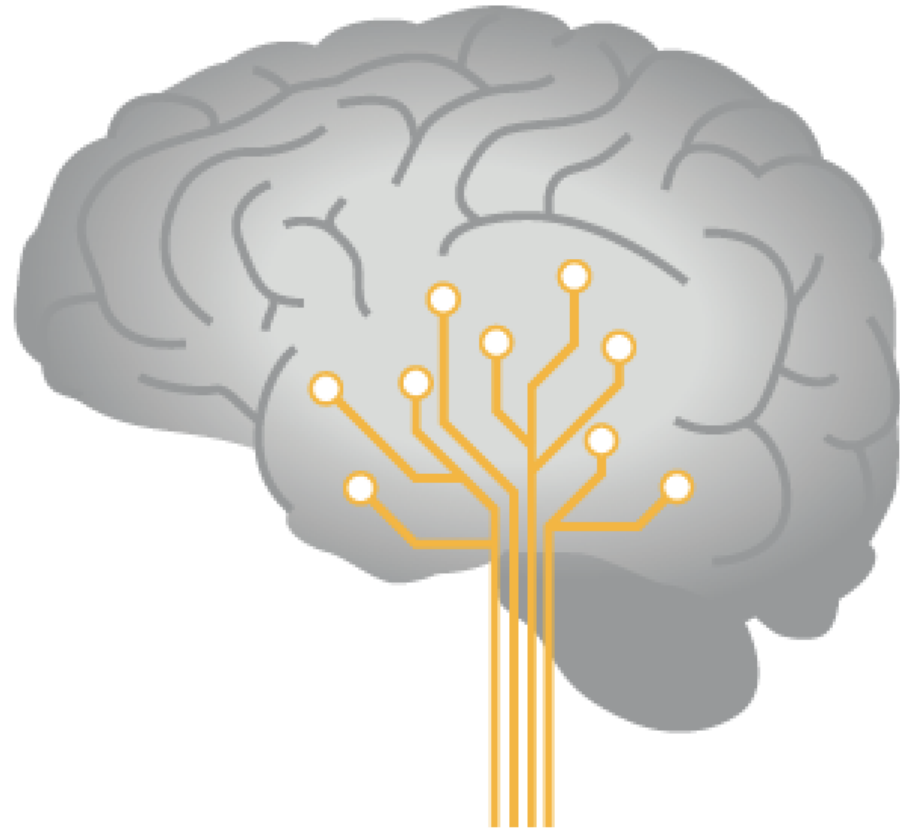

# Human Decision Making: System 1 vs. System 2

## Two Decision Making Routes

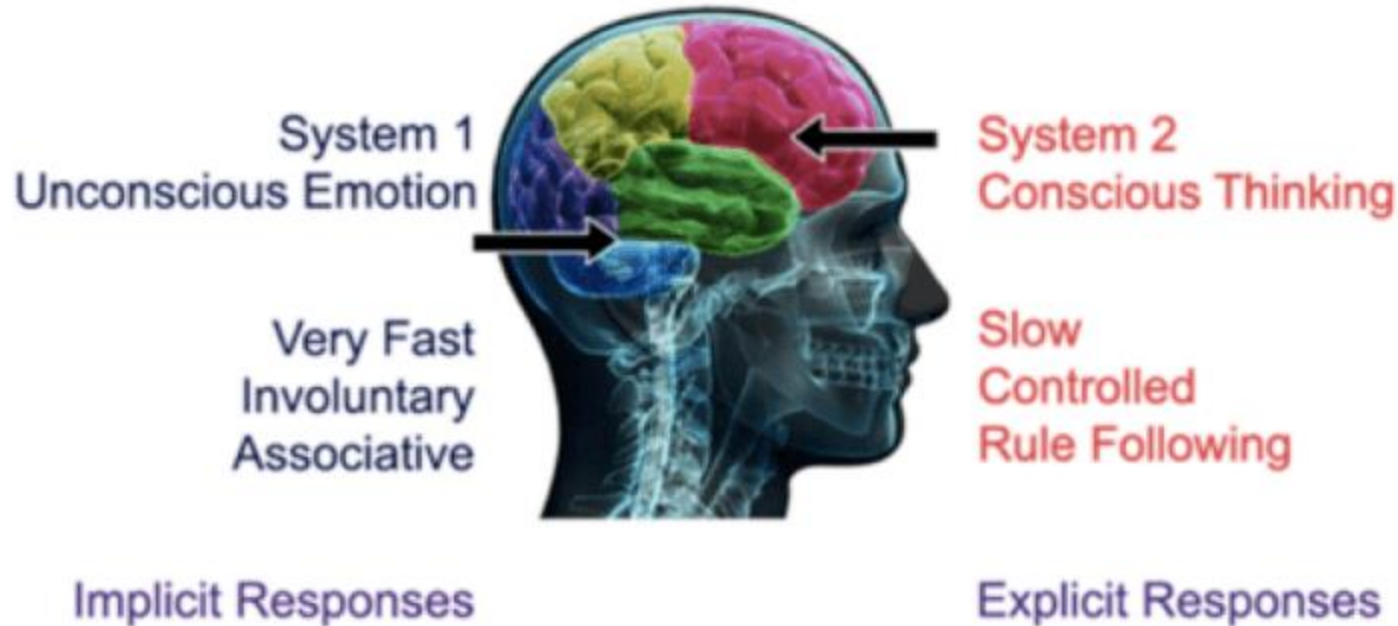



## 3M Pf14.0W Widescreen Privacy Filter(16:9)

Brand: 3M

★★★★☆ 595 ratings

| 20 answered questions



10 Days  
Replacement



1 Year  
Warranty

Available from these sellers.

New (2) from ₹ 3,850.00 + FREE Shipping

- Fits screen sizes of 14" diagonally measured (Width 12 3/16",Height 6 13/16")
  - Protects on screen data when viewed from the side keeping your electronic information confidential making it excellent for use in high traffic areas.
  - Provides 1.5 times more effective privacy than competitive models.
  - Helps protect your fragile LCD screen from damage
  - Reversible;Choose glossy or matte side
- › [See more product details](#)





0

1 2 3 4 5 6 7 8 9 10

11 12 13 14 15 16 17 18 19 20

21 22 23 24 25 26 27 28 29 30

31 32 33 34 35 36 37 38 39 40

41 42 43 44 45 46 47 48 49 50

51 52 53 54 55 56 57 58 59 60

61 62 63 64 65 66 67 68 69 70

71 72 73 74 75 76 77 78 79 80

81 82 83 84 85 86 87 88 89 90

91 92 93 94 95 96 97 98 99 100

101 102 103 104 105 106 107 108 109 110

111 112 113 114 115 116 117 118 119 120

121 122 123 124 125 126 127 128 129 130

131 132 133 134 135 136 137 138 139 140

141 142 143 144 145 146 147 148 149 150

151 152 153 154 155 156 157 158 159 160

161 162 163 164 165 166 167 168 169 170

171 172 173 174 175 176 177 178 179 180

181 182 183 184 185 186 187 188 189 190

191 192 193 194 195 196 197 198 199 200

The First  
Commercial  
Document  
Re construction  
Tool in the World!

SURE PASS

CYBER  
PATRIOT



Indian Cyber  
Institute

Supported by



Information Security  
Education & Awareness

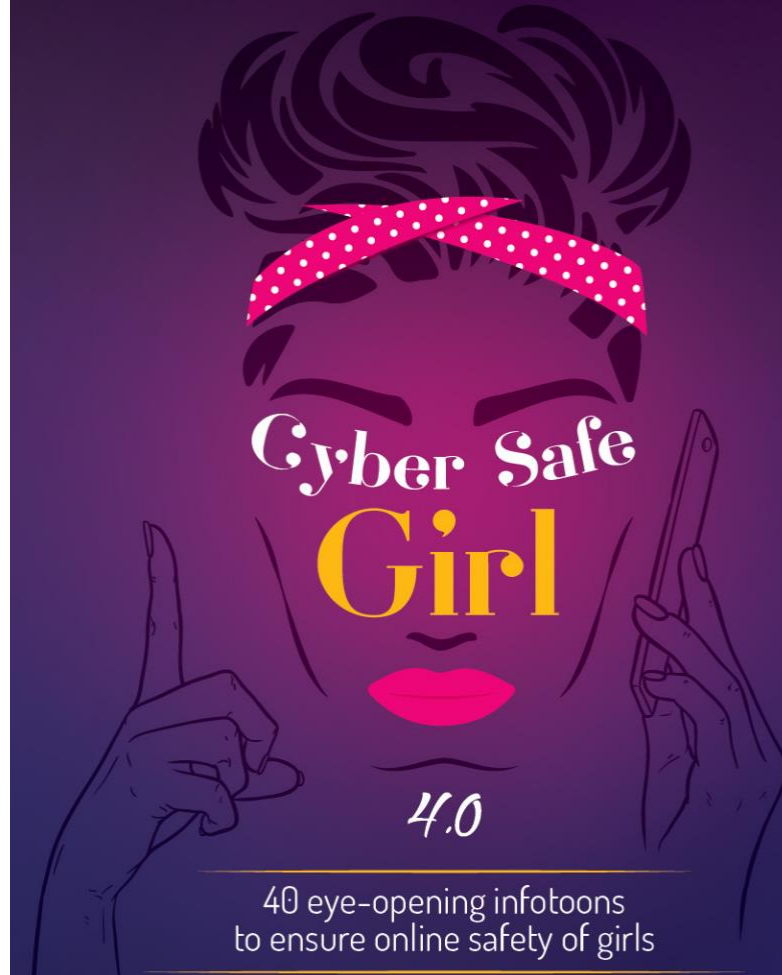

40 eye-opening infotoons  
to ensure online safety of girls

**Ananth Prabhu G** PhD, Post Doctoral Fellow

[www.cybersafegirl.com](http://www.cybersafegirl.com)

Co-Authors : **Adv Prashant Jhala** & **Yashavantha Kumar KN** DySP



# Index

MOBILE RECHARGE SHOP	CYBER VULTURES
DEBIT CARD CLONING	APP TRAPS
KEYLOGGER	JUICE JACKING
SMS SPOOFING	WIFI HACKING
CALL SPOOFING	ONLINE RADICALIZATION
RANSOMWARE	HONEY TRAP
CYBER STALKING	QR CODE SCAM
PICTURE MORPHING	RFID CLONING
PROFILE HACKING	DRONE SURVEILLANCE
ONLINE GAMES	SEARCH ENGINE RESULTS SCAM
JOB CALL LETTER	IDN HOMOGRAPH ATTACK
DEEPPAKES	SCRATCH CARD SCAM
DATING WEBSITE	SIM SWAP
CAMERA HACKING	CRYPTOJACKING
SOCIAL TROLLING	VIDEO CONFERENCE SCAM
PONZI SCHEME	KIDS MOBILE PHONE
FAKE MATRIMONIAL PROFILE	SMART HOMES
MOBILE REPAIR SHOP	MICRO LOANS
FAKE REVIEWS	BLUE SNARFING
FAKE PROFILE WITH SEXTORTION	STOLEN PHONE





IDN HOMOGRAPH ATTACK

<p>SUCHETA WANTS TO SEND MONEY TO HER MOTHER, WHO LIVES IN ANOTHER CITY</p>	<p>SHE RECEIVES A MESSAGE FROM HER BANK</p>	<p>THE MESSAGE WHEN OPENED READ AS FOLLOWS</p>
<p>EXCITED, SHE CLICKS ON THE LINK AND ENTERS HER LOGIN CREDENTIALS.</p>	<p>THE PAGE DID NOT LOAD UPON PRESSING SUBMIT. INSTEAD, SHE GOT THE LOGIN PAGE AGAIN.</p>	<p>SHE ONCE AGAIN ENTERS AND DOES A SUCCESSFUL TRANSACTION.</p>
<p>INSTEAD OF GIFT VOUCHER, SHE GETS A SHOCK TO SEE RS 10000 DEBITED FROM HER ACCOUNT</p>	<p>SUCHETA WAS A VICTIM OF IDN HOMOGRAPH ATTACK WHERE FAKE DOMAINS ARE CREATED THAT MIMIC REAL ONES</p>	<p>HAD SHE UPDATED HER BROWSER SHE WOULD HAVE GOT AN ALERT MESSAGE OF THE FAKE CYRILLIC DOMAIN, THAT MIMICS THE LATIN DOMAIN.</p>



*graze*

# The Tale of Two Links

[www.amazon.com](http://www.amazon.com)

[www.amazon.com](http://www.amazon.com)



Text message 2



◇ | Good M

@ Å Ä Ã Â Á À | 8 9 0  
| | K L

↑ Z X C V B N M ⊗

123 😊 , Microsoft SwiftKey . ↵

□ ○ ◀

## IDN HOMOGRAPH ATTACK

An IDN homograph attack is similar to another type of domain name spoofing known as typosquatting. Both techniques attempt to deceive users by using a new domain name that's similar to an established name, although they exploit different types of similarities.

### Sections Applicable

- IT Act Section 66** - Computer related offences
- IT Act Section 66C** - Punishment for Identity Theft
- IT Act Section 66D** - Punishment for cheating by personation using a computer resource
  
- IPC Section 419** - Punishment for cheating by personation
- IPC Section 420** - Cheating



# Punycode converter

or an IDN converter, a tool for Punycode to Text/Unicode and vice-versa conversion

## Text

Example: 點看

Copy

Convert to Punycode >>

## Punycode

Example: xn--c1yn36f

Copy

<< Convert to text

SCRATCH CARD SCAM

		
<p>AMRIN IS IN FINANCIAL CRUNCH AND VERY MUCH WORRIED.</p>	<p>SHE WISHES FOR SOME MIRACLE TO HAPPEN WHERE SHE GETS INR 2 LAKHS.</p>	<p>SHE RECEIVES A SCRATCH CARD IN A WHATSAPP GROUP TO WIN UPTO 5 LAKHS.</p>
		
<p>AMRIN CLICKS ON THE LINK, SCRATCH CARD LOADS, SHE EAGERLY SCRATCHES THE CARD</p>	<p>SHE WINS INR 3 LAKHS, SHE THANKS GOD FOR ANSWERING HER PRAYERS.</p>	<p>THE WALLET APP OPENS AND IT PROMPTS FOR PIN NUMBER.</p>
		
<p>THE TRANSACTION WAS FOR PAY, INSTEAD OF RECEIVE WHICH AMRIN HADN'T CHECKED.</p>	<p>AMRIN ENTERS THE PIN ONLY TO LOOSE HER HARD EARNED INR 30,000.</p>	<p>SHE WAS UNAWARE THAT WALLETS DO NOT ASK PIN FOR RECEIVING MONEY.</p>

## SCRATCH CARD SCAM

A user receives a message with a link to a third-party website with a promise of winning guaranteed money. When the user clicks on the link, it redirects to a website with a scratch card mimicking the design of popular Pay Wallets scratch card.

### Sections Applicable

- IT Act Section 66** - Computer related offences
- IT Act Section 66C** - Punishment for Identity Theft
- IT Act Section 66D** - Punishment for cheating by personation using a computer resource
  
- IPC Section 419** - Punishment for cheating by personation
- IPC Section 420** - Cheating



You've won  
₹899

SIM SWAP

<p>ARPTHA HAD LINKED HER MOBILE NUMBER FOR AUTHENTICATION ON MANY APPS THAT SHE USED ON HER CELL PHONE.</p>	<p>FEW OF THEM WERE MOBILE WALLETS, 2FA FOR EMAIL, BANK ACCOUNTS, SOCIAL MEDIA ETC.</p>	<p>ONE NIGHT ARPITHA GETS A CALL FROM A CYBER CRIMINAL WHO PRETENDS TO BE CALLING FROM HER CELL PHONE COMPANY.</p>
<p>HE CONVINCES HER TO KEEP HER PHONE OFF FOR 2 HOURS, FOR A BONUS 5G ACTIVATION ONLY TO LIMITED CUSTOMERS.</p>	<p>ARPTHA SWITCHES OFF HER PHONE AND GOES TO SLEEP. NEXT MORNING WHEN SHE WAKES UP, THERE IS NO NETWORK.</p>	<p>THE HACKER HAD SUBMITTED HER DOCUMENTS AND OPTED FOR NEW SIM, AS THE NEW SIM GETS ACTIVATED, THE OLD ONE BECOMES USELESS.</p>
<p>USING FORGOT PASSWORD AND OTP VERIFICATION OPTIONS, THE HACKER GAINS CONTROL OF ALL HER ACCOUNTS.</p>	<p>HE ALSO GETS CONTROL OF HER WHATSAPP, MAKING HIM ACCESS HER PRIVATE CHATS/PHOTOS, TO BLACKMAIL HER.</p>	<p>VIA VISHING/SMISHING/PHISHING HACKERS ALSO REQUEST OTP TO HACK INTO WHATSAPP AND OTHER ACCOUNTS WITHOUT SIM SWAP.</p>



## SIM SWAP

A SIM swap scam (also known as port-out scam, SIM splitting, Smishing and simjacking, SIM swapping) is a type of account takeover fraud. The fraud exploits a mobile phone service provider's ability to seamlessly port a telephone number to a device containing a different SIM. This feature is normally used when a customer has lost or had their phone stolen, or is switching service to a new phone.

### Sections Applicable

- IT Act Section 66** - Computer related offences
- IT Act Section 66C** - Punishment for Identity Theft
- IT Act Section 66D** - Punishment for cheating by personation using a computer resource
  
- IPC Section 419** - Punishment for cheating by personation
- IPC Section 420** - Cheating

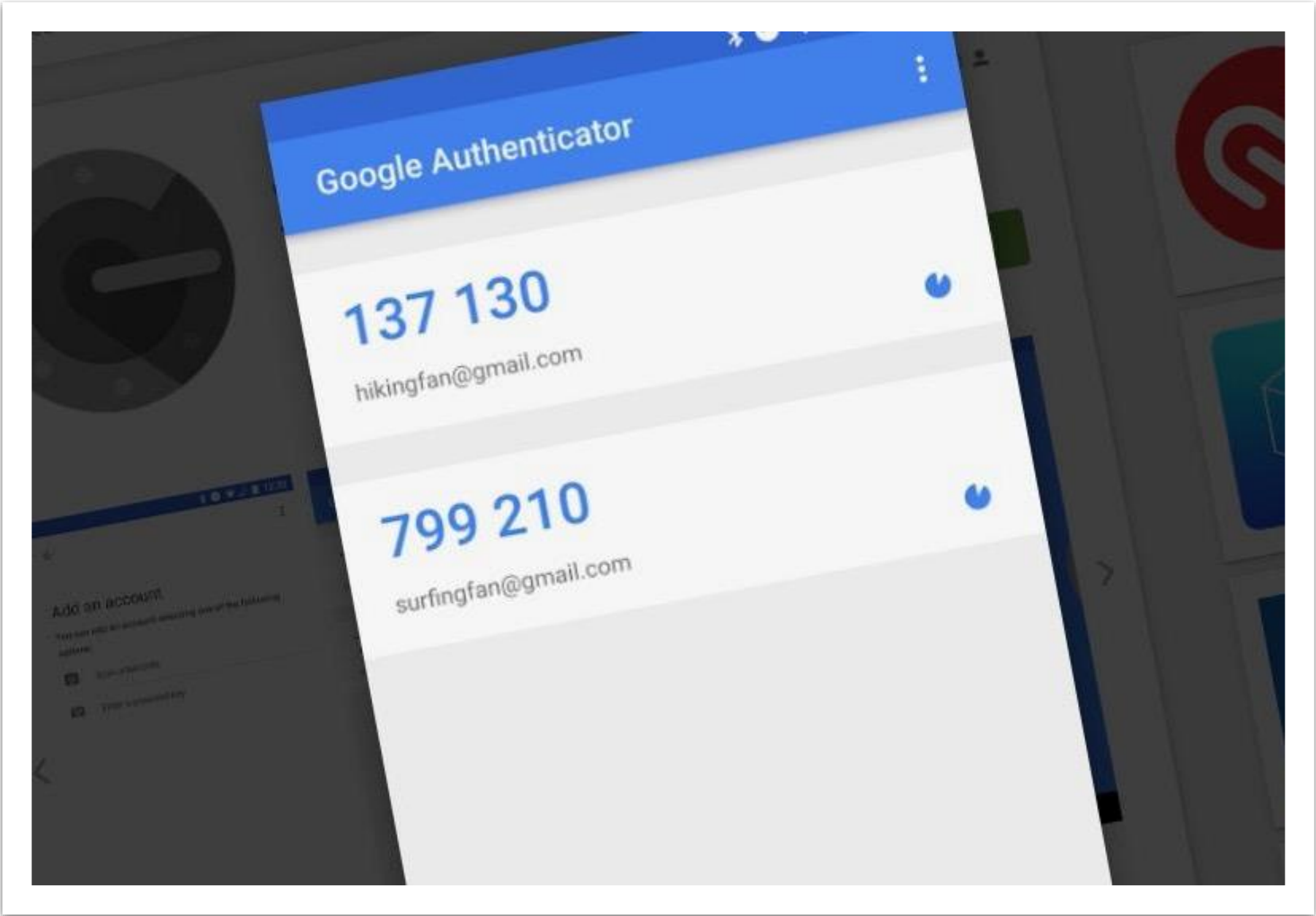

Google Authenticator







137 130

hikingfan@gmail.com

799 210

surfingfan@gmail.com

CRYPTOJACKING

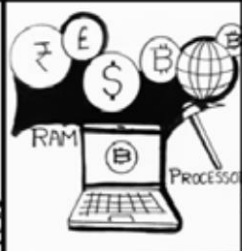
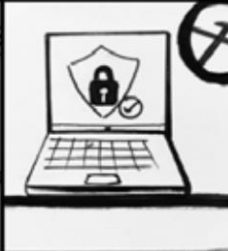
		
<p>ROOPA IS A SOFTWARE DEVELOPER AND WORKS FROM HOME.</p>	<p>SHE USES 2 HIGH END LAPTOPS TO EXECUTE HER CODE WHICH ARE RESOURCE INTENSIVE.</p>	<p>OFF LATELY, SHE NOTICED HER SYSTEMS TO BE MUCH SLOWER THAN USUAL.</p>
		
<p>ALSO, THE POWER USAGE OF THE SYSTEM HAD GONE UP DRASTICALLY.</p>	<p>UPON OPENING THE PROCESS MANAGER, SHE COULD SEE SOME UNKNOWN APPS RUNNING.</p>	<p>THESE APPS WERE CRYPTOJACKING APPS THAT CONSUMED HER RESOURCES TO MINE BITCOINS.</p>
		
<p>SHE HAD CLICKED ON AN UNKNOWN LINK THROUGH WHICH THIS APP WAS INSTALLED.</p>	<p>USING HER SYSTEMS RAM AND PROCESSOR, THE CYBER CRIMINAL EARNS A LOT OF MONEY BY MINING.</p>	<p>HAD SHE INSTALLED A GOOD PAID ANTIVIRUS AND BROWSER EXTENSION TO BLOCK COIN MINING, THE SYSTEM WOULD HAVE BEEN SAFE.</p>

## CRYPTOJACKING

It is a type of cyberattack in which a hacker co-opts a target's computing power to illicitly mine cryptocurrency on the hacker's behalf. Cryptojacking can target individual consumers, massive institutions, and even industrial control systems. It slows down infected computers, as the mining process takes priority over other legitimate activities.

### Sections Applicable

- IT Act Section 66** – Computer related offences
- IT Act Section 66C** – Punishment for Identity Theft
- IT Act Section 66D** – Punishment for cheating by personation using a computer resource
  
- IPC Section 419** – Punishment for cheating by personation
- IPC Section 420** – Cheating

Section of Prevention of Money Laundering Act, 2002 (PMLA), may apply as per the facts of the case.

## DETECTING CRYPTOJACKING



- 1 Be aware of decrease in performance** in computing devices.
- 2 Look for overheating of devices** and running fans for cooling.
- 3 Monitor computer** for an increase in CPU usage.
- 4 Check for coding** and file changes on your site.
- 5 Scan for malware** to monitor your websites.
- 6 Follow crypto-news** and look for parallels on your site.



# PREVENTING CRYPTOJACKING



**Train your IT Team** to detect cryptojacking.



**Use anti-cryptomining** browser extensions.



**Educate employees** not to click on links in emails.



**Disable JavaScript** to block cryptomining code.



**Use ad-blockers** to block malicious code in online ads.

VIDEO CONFERENCE SCAM

		
<p>AMRITA WORKS FOR A MNC AS A TEAM LEAD. OFF LATELY, SHE HAD OPTED FOR WORK FROM HOME.</p>	<p>SHE USED TO REGULARLY HOST ONLINE MEETINGS TO COORDINATE WITH HER TEAM MEMBERS.</p>	<p>EVEN THE CLIENTS AT TIMES USED TO INTERACT VIA VIDEO CONFERENCE TO CHECK FOR PROGRESS AND SUGGEST CHANGES.</p>
		
<p>ONE MORNING, DURING THE CLIENT MEETING, A RANDOM USER LOGS IN AND POSTS A PORN CLIP.</p>	<p>EMBARRASSED BY THE EVENT, AMRITA LOGGED OFF.</p>	<p>SHE HAD MADE THE MISTAKE OF POSTING THE MEETING ID AND PASSWORD IN THE SAME MESSAGE IN A DISCUSSION FORUM.</p>
		
<p>A DISGRUNTLED EMPLOYEE FROM THE CLIENTS SIDE LOGGED IN WITH A PROXY NAME.</p>	<p>THE WAITING ROOM WAS NOT ENABLED TO SCREEN THE PARTICIPANTS.</p>	<p>PERMISSION TO SHARE SCREEN AND FILE SHARE WAS NOT DISABLED FOR ALL THE PARTICIPANTS.</p>

## VIDEO CONFERENCE SCAM

There has been a mass adaptation of online platforms to conduct meetings, online classes, conferences without giving much consideration to the security settings of these platforms. This has paved the way for cyber criminals to take advantage of loopholes for malicious purposes.

### Sections Applicable

- IT Act Section 66** - Computer related offences
- IT Act Section 66C** - Punishment for Identity
- IT Act Section 67** - Publishing or transmitting obscene content
- IT Act Section 67A** - Publishing or transmitting sexually explicit acts or conduct

### **Theft**

- IT Act Section 66D** - Punishment for cheating by personation using a computer resource  
(as per the facts of the case)
- IPC Section 419** - Punishment for cheating by personation
- IPC Section 420** - Cheating (as per the facts of the case)

1. Require passwords for all meetings

2. The chairperson joins first and enables waiting room

3. Lock calls after everyone joins

4. Do not reuse meeting ID

5. Set up alerts when meetings are forwarded

6. Limit file sharing and screen sharing.

7. Prevent Recording of meeting

8. Use business or enterprise license

9. Do not share meeting ID and password in the same message.

10. Update the software of the video conference

KIDS MOBILE PHONE

		
<p>SUMAN IS A SINGLE MOTHER. LIVES WITH HER 9 YEAR OLD SON ARNAAV.</p>	<p>SHE WORKS AS A BEAUTICIAN AT A PARLOUR CLOSE TO HER HOUSE.</p>	<p>BECAUSE OF THE PANDEMIC, ALL THE CLASSES ARE ONLINE. ARNAAV ATTENDS CLASSES VIA HIS MOTHERS MOBILE PHONE.</p>
		
<p>INSTEAD OF ATTENDING CLASSES, ARNAAV PLAYS VIDEO GAMES.</p>	<p>HE ALSO DOWNLOADS PAID APPS FROM THE PLAY STORE USING THE CREDIT CARD WHICH IS STORED.</p>	<p>SOMETIMES, HE EVEN BUYS COINS IN THE VIDEO GAMES TO COMPLETE THE LEVEL FASTER.</p>
		
<p>HE DELETES THE TRANSACTION MESSAGE RECEIVED VIA SMS SO THAT HIS MOTHER DOES NOT FIND OUT.</p>	<p>SUMAN WAS SHOCKED TO SEE RS 14000 SWIPED AT PLAY STORE IN HER MONTHLY CREDIT CARD BILL.</p>	<p>HAD SHE ENABLED PARENTAL CONTROLS ON IOS/ANDROID, ARNAAV COULD USE THE PHONE ONLY FOR ACADEMIC PURPOSES.</p>





## KIDS MOBILE PHONE

Children are using devices at a younger age and it's a tricky situation for most parents since they do not want their child to come across adult, abusive, or violent content on the internet. Thus, it's important to consider setting controls on the devices they use. Responsible mobile phone use is about managing costs, sticking to family rules, keeping phones safe and being respectful.

### Sections Applicable

#### **If Gambling is involved:**

The acts may attract Provisions of

**Section 69A** - IT Act for blocking illegal gambling websites.

The Public Gambling Act, 1867.

The Foreign Exchange Management Act, 1999 (FEMA).

The Lotteries Regulation Act of 1998.

A few States have made provisions for laws on Gambling.

#### **Exceptions:**

1. Horse racing is legal in India
2. Lottery system (in few States)
3. The Public Gambling Act of 1867 exempts skill-based games from the definition of gambling.



		
<p>SHAZIA IS A TECH SAVVY HOUSE WIFE. SHE LIKES TO INSTALL THE LATEST GADGETS AT HOME.</p>	<p>SHE HAD VISITED A SHADY MARKET, WHERE CHEAP INTERNET OF THINGS (IOT) SALE WAS GOING ON.</p>	<p>SHE WAS EXCITED TO SEE MANY PRODUCTS ON SALE- UPTO 60% OFF</p>
		
<p>SHAZIA BUYS A SMART BULB AND INSTALLS IT IN HER BEDROOM</p>	<p>THE BULB CAN BE CONTROLLED FROM HER PHONE, WHERE SHE CAN CHANGE THE COLOR OF THE LIGHT AND ALSO SWITCH ON/OFF.</p>	<p>HARDLY DID SHE KNOW, THE WIFI CONNECTED BULB ALSO HAD A NANO CAMERA INSIDE IT.</p>
		
<p>THE CAMERA RECORDED ALL THE ACTIVITIES IN HER BEDROOM AND UPLOADED IT TO THEIR SERVER.</p>	<p>BARELY DID SHE KNOW THAT IOT DEVICES SHOULD BE PROCURED ONLY FROM GENUINE VENDORS AND THE SECURITY SETTINGS SHOULD BE IN PLACE.</p>	<p>ANY DEVICE WHICH IS INTERNET ENABLED CAN BE USED FOR SNOOPING. TECHNOLOGY IS A DOUBLE EDGED SWORD.</p>



## SMART HOMES

Smart-home devices hold a treasure trove of personal information, from your birth date to credit card details, that cybercriminals can steal via hacking if the devices lack robust protections to thwart attacks. They can then use the stolen data to launch targeted attacks to rope you into shady deals.

### Sections Applicable

- IPC Section 354** - Sexual harassment
- IPC Section 354C** - Voyeurism
- IPC Section 509** - Outraging modesty of women
  
- IT Act Section 66** - Computer related offences
- IT Act Section 66E** - Punishment for violation of privacy





1. ENABLE ROUTER  
SECURITY SETTINGS.



2. USE A STRONG  
ENCRYPTION  
METHOD FOR WI-FI.

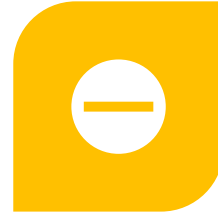

3. DISABLE FEATURES  
YOU MAY NOT NEED.



4. KEEP YOUR  
SOFTWARE UP TO  
DATE.



5. DO THE TWO-  
STEP.

MICRO LOANS

		
<p>SAMANTHA IS A FINAL YEAR ENGINEERING STUDENT LIVING IN A PG NEAR TO HER COLLEGE.</p>	<p>HER PARENTS USED TO TRANSFER RS 5000 EVERY MONTH FOR HER EXPENSES.</p>	<p>SAMANTHA WAS UNABLE TO GET CAMPUS PLACED AS SHE HAD NO ADDITIONAL CERTIFICATIONS.</p>
		
<p>TO ENROL FOR AN ONLINE COURSE, SHE WANTED RS 10000 AND WAS HESITANT TO ASK HER PARENTS AS THEY WERE IN A FINANCIAL CRUNCH.</p>	<p>AN AD APPEARS WHILE BROWSING, WHICH PROMISES TO DISBURSE RS 10000 WITHOUT ANY DOCUMENTATION. HAPPILY SHE INSTALLS THE APP.</p>	<p>IN SPITE OF COMPLETING THE COURSE, SHE DID NOT GET PLACED. THEREFORE, SHE WAS UNABLE TO REPAY THE LOAN.</p>
		
<p>HARDLY DID SHE KNOW, THE APP HAD REGULARLY ACCESSED HER FRIEND LIST, CONTACTS, LOCATION AND EVEN OTHER DATA FROM HER PHONE.</p>	<p>THE CUSTOMER CARE OF THE LOAN SHARK APP STARTED CALLING, ABUSING AND THREATENING HER AND HER FRIENDS FROM HER CONTACTS.</p>	<p>MANY LOAN SHARK APPS EVEN SEND BULLIES TO RECOVER THE AMOUNT AND ALSO LEVY HEAVY INTEREST ON THE LOAN AVAILABLE.</p>

## MICRO LOANS

Fly-by-night micro lending illegal app-based financiers are thriving. These moneylenders target younger customers who look for quick loans for consumption purposes. Those failing to pay up will have their photos shared in their family and workplace social media groups, a tactic that has driven many to desperation.

### Sections Applicable

- IPC Section 420** - Cheating
  - IPC Section 503/506** - Criminal Intimidation
  - IPC Section 383** - Extortion
  - IPC Section 306** - Abetment of Suicide
  - IPC Section 499/500** - Defamation
  - IPC Section 120B** - Criminal Conspiracy
  - IPC Section 34** - Common Intention
- Sections of Reserve Bank of India Act, 1934  
(as per the facts of the case)

As per the official website of The Central Bank of India - RBI, the following 12 banks are listed

1. Bank of Baroda
2. Bank of India
3. Bank of Maharashtra
4. Canara Bank
5. Central Bank of India
6. Indian Bank
7. Indian Overseas Bank
8. Punjab and Sind Bank
9. Punjab National Bank
10. State Bank of India
11. UCO Bank
12. Union Bank of India

BLUE SNARFING

		
<p>ALIA WANTED TO ATTEND ONLINE LECTURES. THEREFORE SHE BOUGHT A CHEAP TAB FROM A GREY MARKET.</p>	<p>SHE ALWAYS KEPT THE BLUETOOTH ON, AS HER EARPODS WERE ALWAYS CONNECTED TO THE TAB.</p>	<p>HER NEIGHBOR, ANUSH HAD MASTERED A FEW HACKING SKILLS BY GOING THROUGH THE COURSES IN THE DARK WEB.</p>
		
<p>HE DOWNLOADS A TOOLKIT WHICH CAN PAIR THE DIGITAL DEVICE WITH ANY DEVICE HAVING VULNERABILITIES.</p>	<p>REALIZING BLUETOOTH HAS A FAIRLY GOOD RANGE OF 10 METERS, HE COVERTLY HIDES IN HER GARDEN AND CONNECTS TO THE TAB.</p>	<p>UPON SUCCESSFUL PAIRING, HE GETS ACCESS TO HER FILES AND FOLDERS. ALSO HER IMEI.</p>
		
<p>HE THEREAFTER FORWARDS THE SMS AND CALLS TO HIS NUMBER.</p>	<p>ALIA FINDS MANY OF HER PHOTOS AND FILES MISSING FROM HER SIM ENABLED TAB. NEITHER SHE GETS ANY CALLS.</p>	<p>HAD SHE SET THE MAC ID OF HER BLUETOOTH AS HIDDEN INSTEAD OF DISCOVERABLE, SHE COULD HAVE BEEN SAFE.</p>



## BLUE SNARFING

It is a device hack performed when a wireless, Bluetooth-enabled device is in discoverable mode. Bluesnarfing allows hackers to remotely access Bluetooth device data, such as a user's calendar, contact list, emails and text messages. This attack is perpetrated without the victim's knowledge.

### Sections Applicable

- IT Act Section 66** - Computer related offences
- IT Act Section 66C** - Punishment for Identity Theft
- IT Act Section 66D** - Punishment for cheating by personation using a computer resource  
(as per the facts of the case)
  
- IPC Section 419** - Punishment for cheating by personation
- IPC Section 420** - Cheating (as per the facts of the case)

1:37

Tue, Oct 20

2 days, 3 hr



No notifications

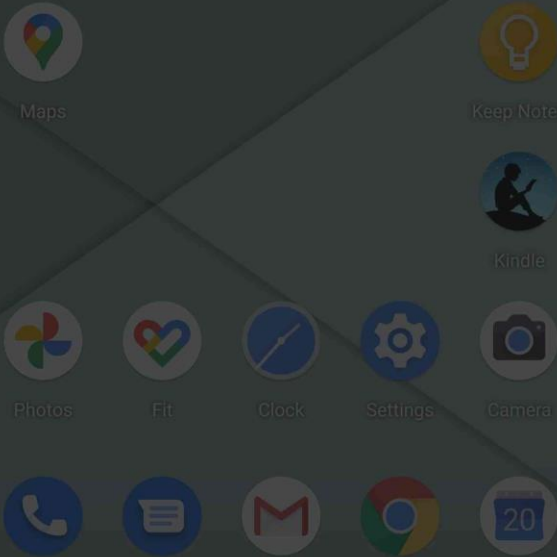

1:35

Phone on vibrate

Verizon



10 (QP1A.191005.007.A3)



STOLEN PHONE

		
<p>ANAMIKA WAS A CELL PHONE ADDICT. SHE USED TO USE SNAPCHAT, WHATSAPP AND INSTAGRAM REGULARLY.</p>	<p>ALONG WITH HER FRIEND DIVYA, SHE GOES TO A CARNIVAL.</p>	<p>LOOKING AT THE FERRIS WHEEL, OUT OF EXCITEMENT, BOTH OF THEM BUY TICKETS AND HOP IN.</p>
		
<p>WITHOUT HER KNOWLEDGE, THE CELL PHONE FROM HER POCKET SLIPS OUT AND FALLS DOWN.</p>	<p>AT THE TOP, SHE PUTS HER HAND IN THE POCKET TO TAKE OUT THE PHONE TO CLICK A SELFIE.</p>	<p>SHELL SHOCKED, SHE REALIZES SHE LOST HER PHONE. SHE CALLS HER NUMBER FROM DIVYAS PHONE.</p>
		
<p>THE PERSON WHO STOLE HER PHONE CUTS THE CALL AND LATER SWITCHES IT OFF.</p>	<p>ANAMIKA COULD HAVE LOGGED INTO THE FIND MY DEVICE PORTAL AND TRACKED HER PHONE.</p>	<p>SHE COULD HAVE ALSO FORMATTED HER PHONE REMOTELY TO PROTECT HER DATA.</p>

## STOLEN PHONE

A stolen phone can leave you feeling helpless and scrambling. Mobile phones and the data they hold are very valuable to thieves. And for similar reasons - they hold so much important personal information of real and sentimental value - a theft can be a huge loss for the owner.

### Sections Applicable

**IPC Section 378/379** - Theft

**IT Act Section 66** - Computer related offences

## Google Find My Device



**Samsung Galaxy S8**

Last seen just now

87%



**PLAY SOUND**



Device will ring for 5 minutes, even if set to silent.



**SECURE DEVICE**



**Lock device and sign out of your Google Account.** You can also display a message or phone number on the lock screen. You can still locate the device after it's locked.



**ERASE DEVICE**



**Erase all content from the device.** After your device has been erased, you can't locate it.

May require sign-in.

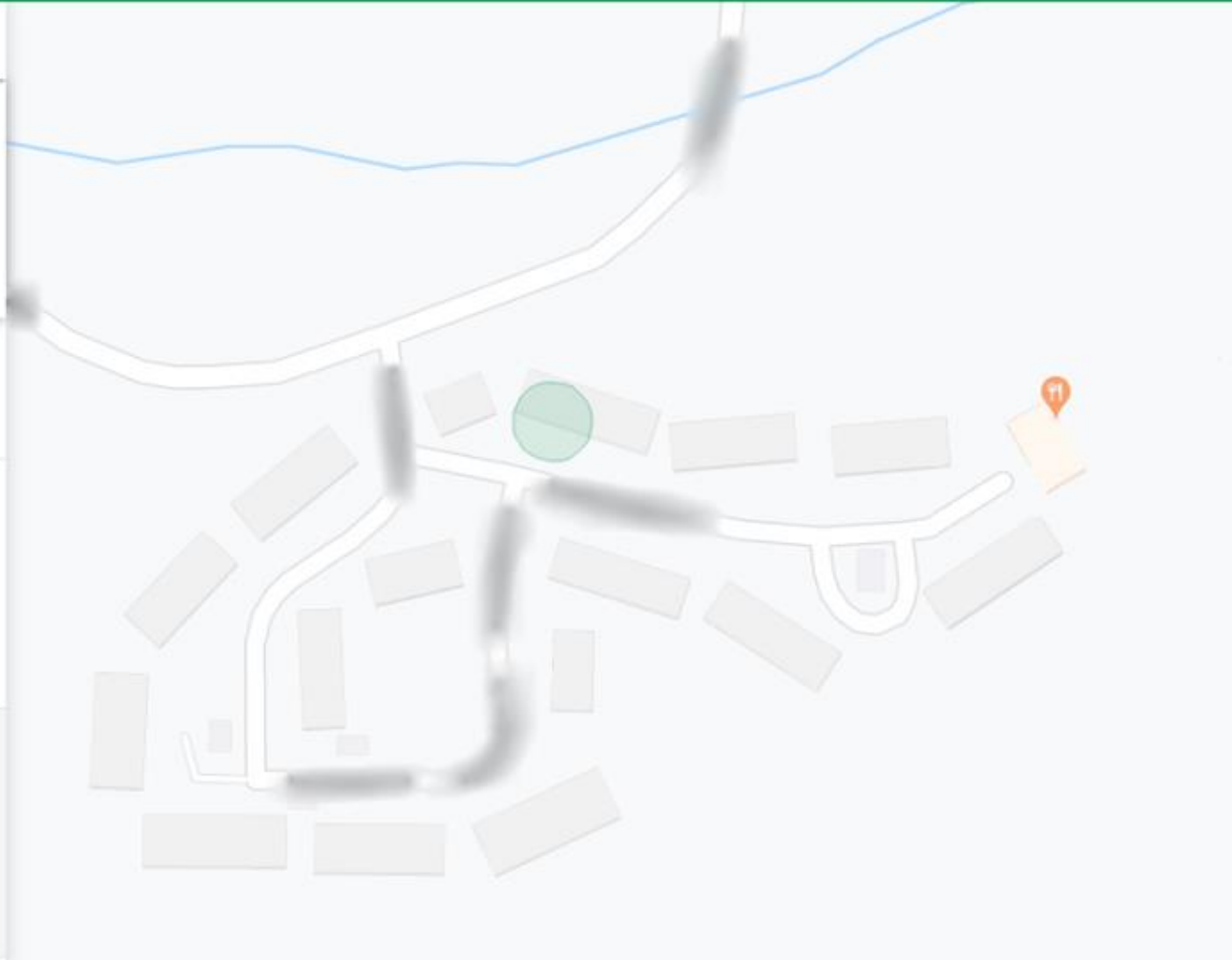







## iParn RFID Aluminium Foil WiFi Credit Debit Card Cover Holder (ATM Card Sleeve 5 Pack\_Silver)

5 RFID CREDIT CARD SLEEVE - atm cover card holder for men stylish,Our secure blocking credit debit card sleeves comes in a Silver Colour. Its smart design fits traditional size ... [more »](#)

**₹299.00**

+₹40.00 delivery

[Amazon.in](#)

[Visit site](#)

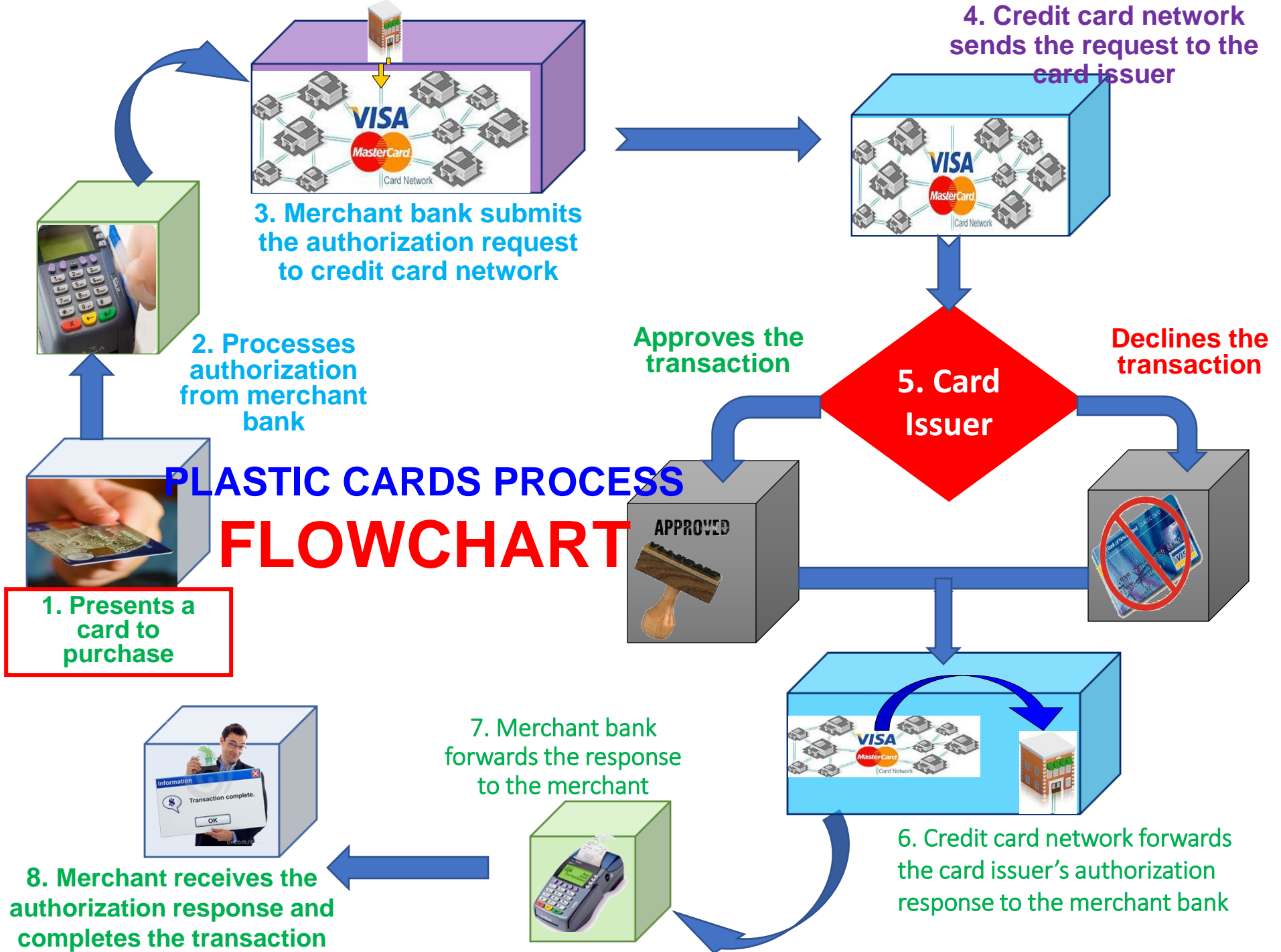

# Probable Scenario / Occurrence of Incident

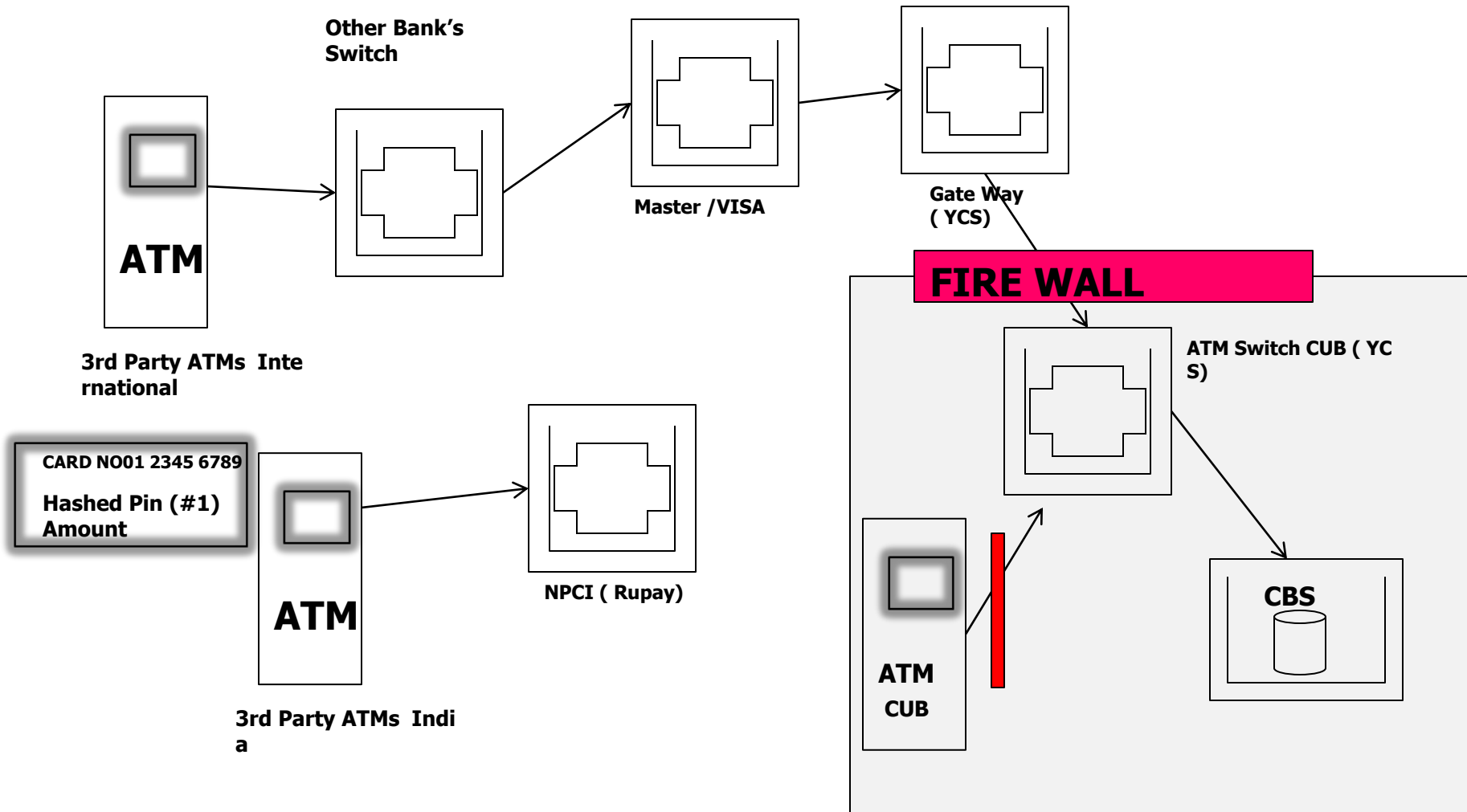

# Probable Scenario / Occurrence of Incident

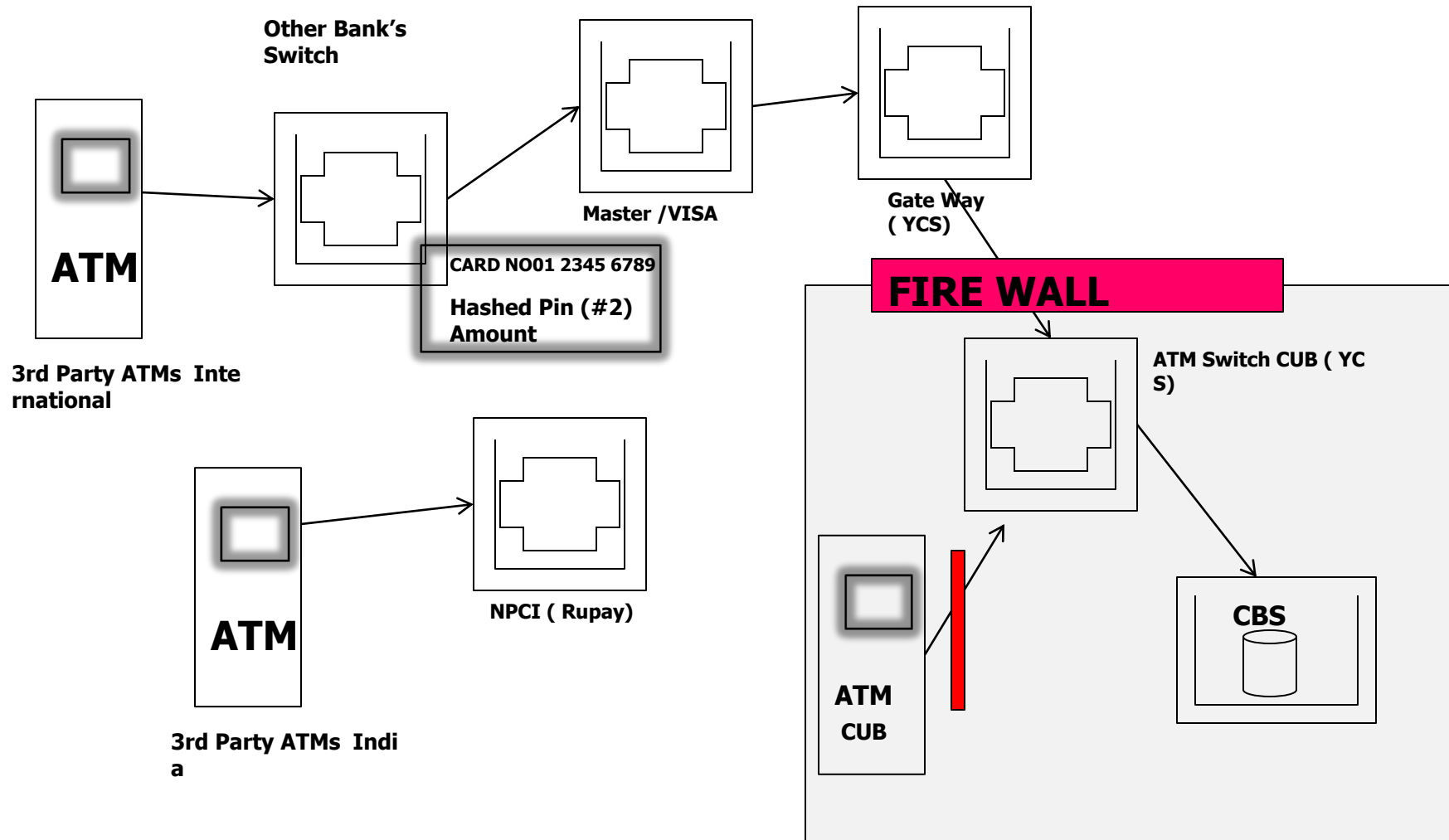



# Probable Scenario / Occurrence of Incident

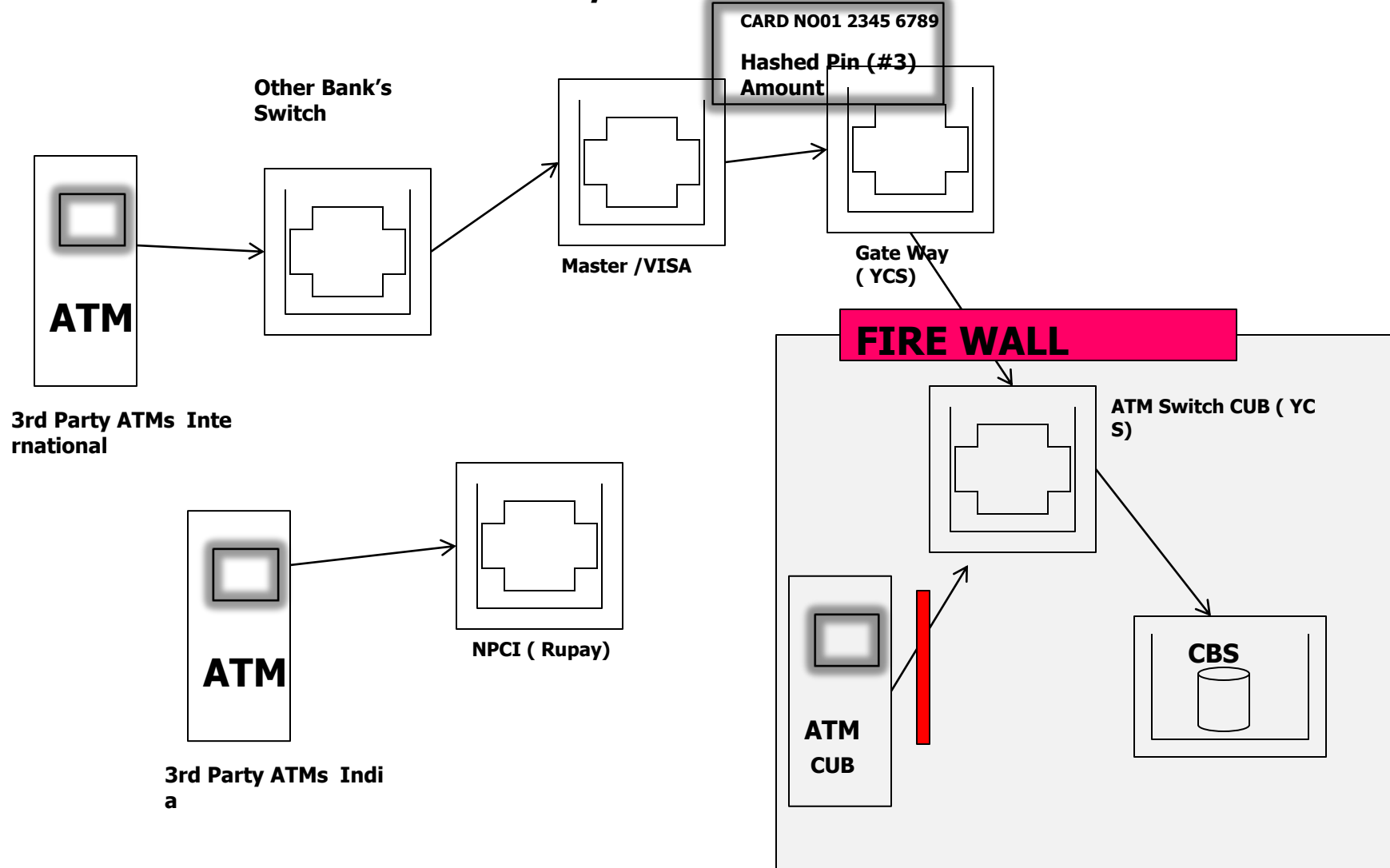

# Probable Scenario / Occurrence of Incident

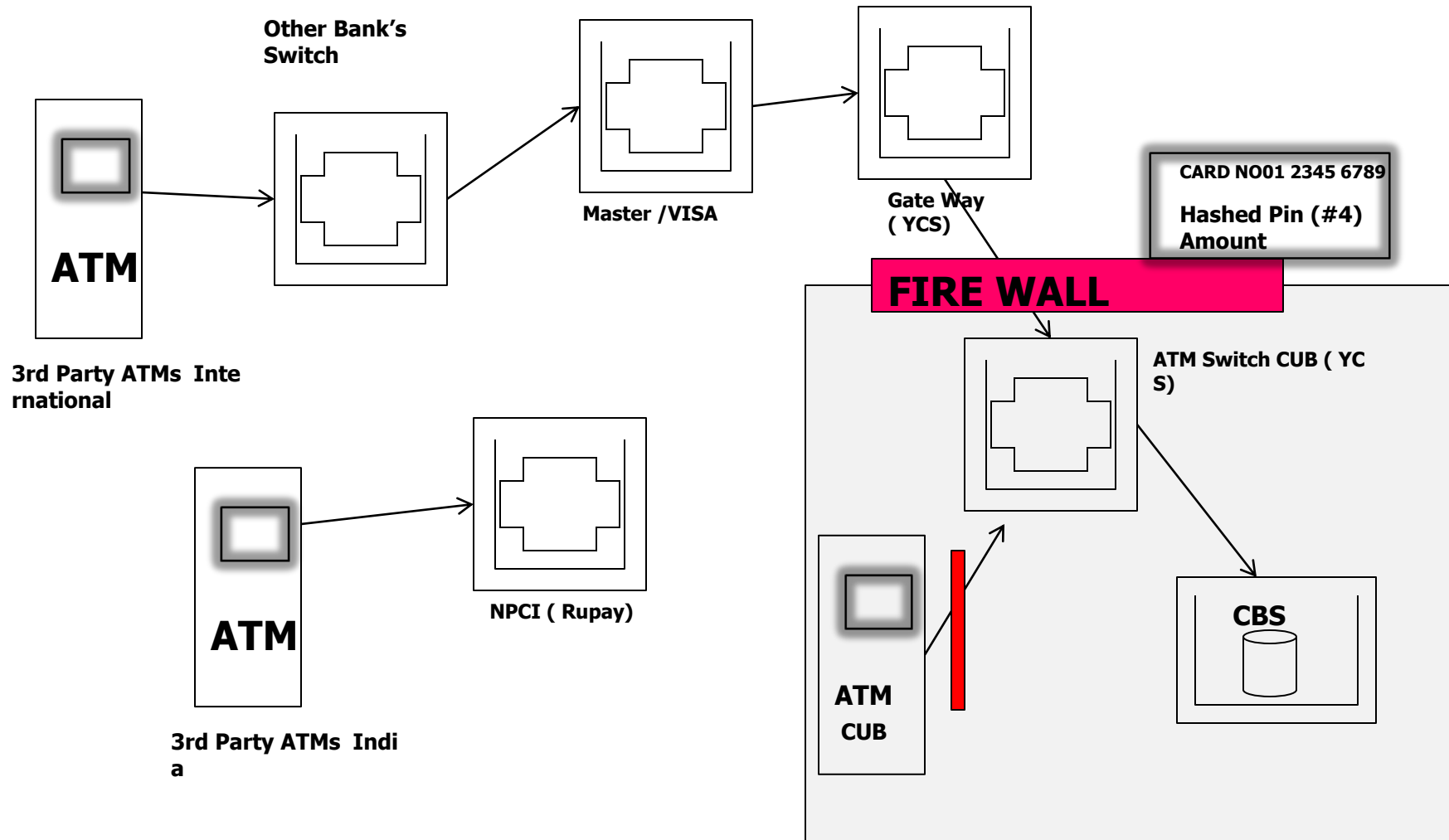

# Probable Scenario / Occurrence of Incident

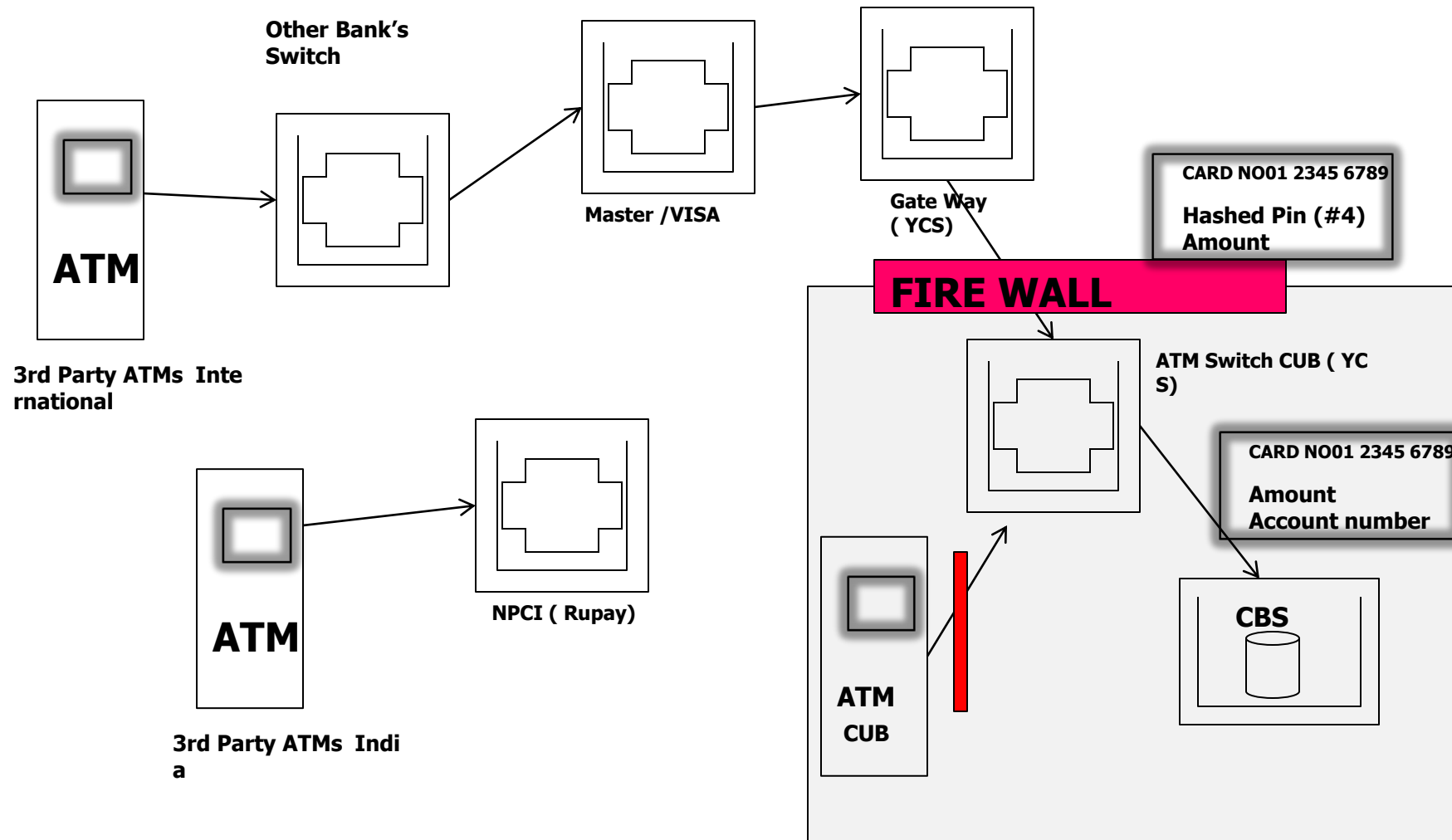

# Probable Scenario / Occurrence of Incident

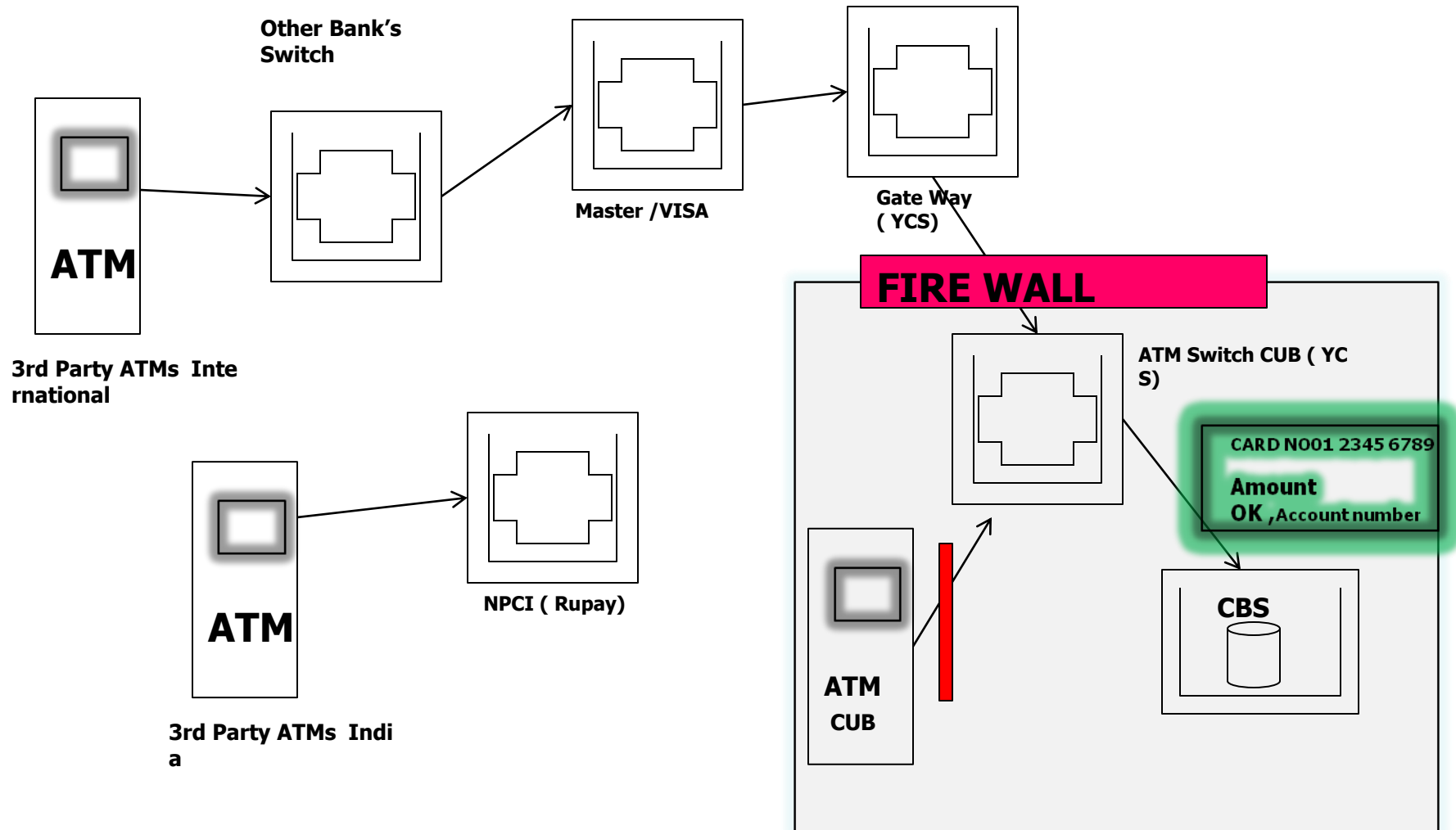

## Probable Scenario / Occurrence of Incident

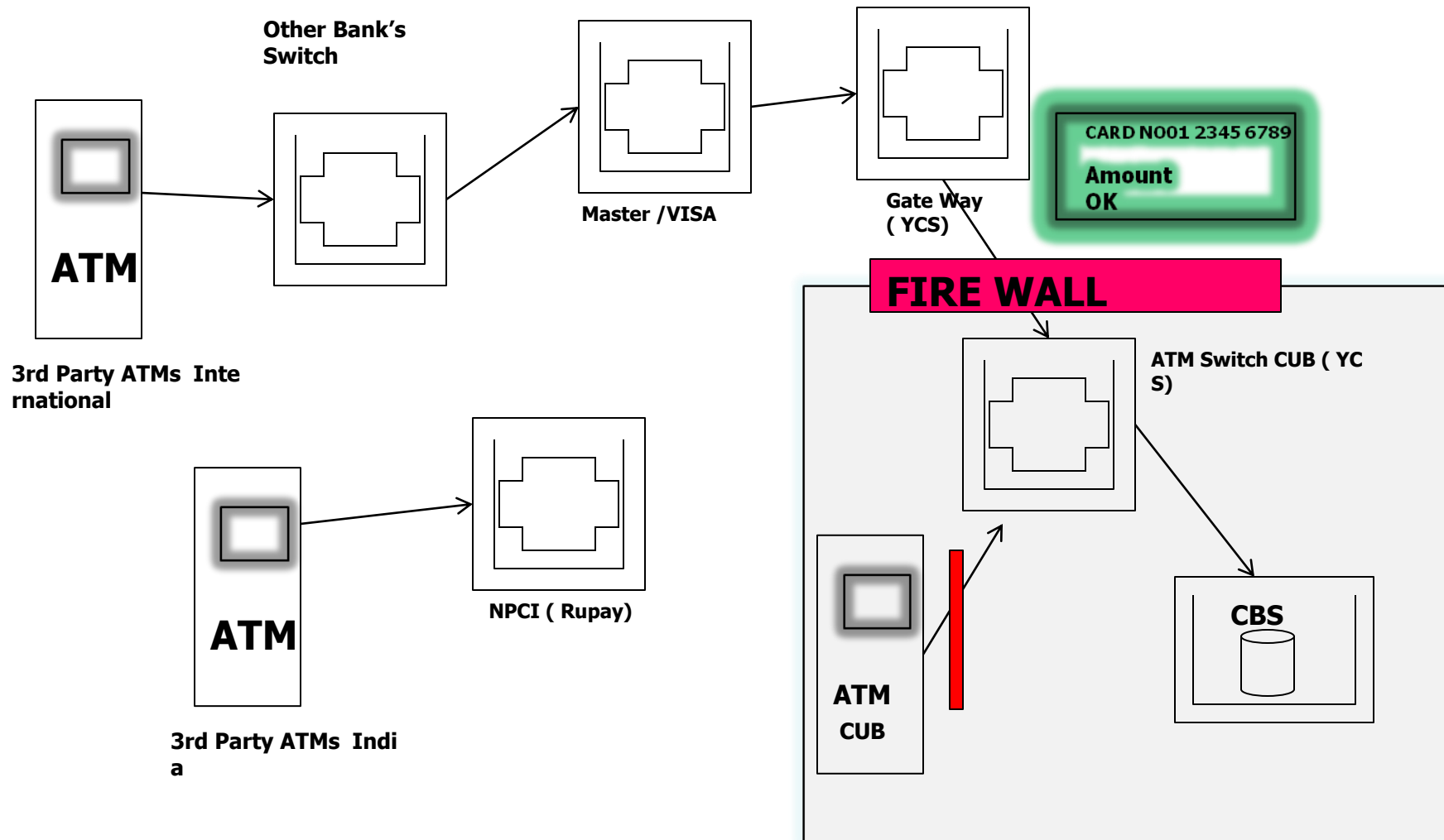



# Probable Scenario / Occurrence of Incident

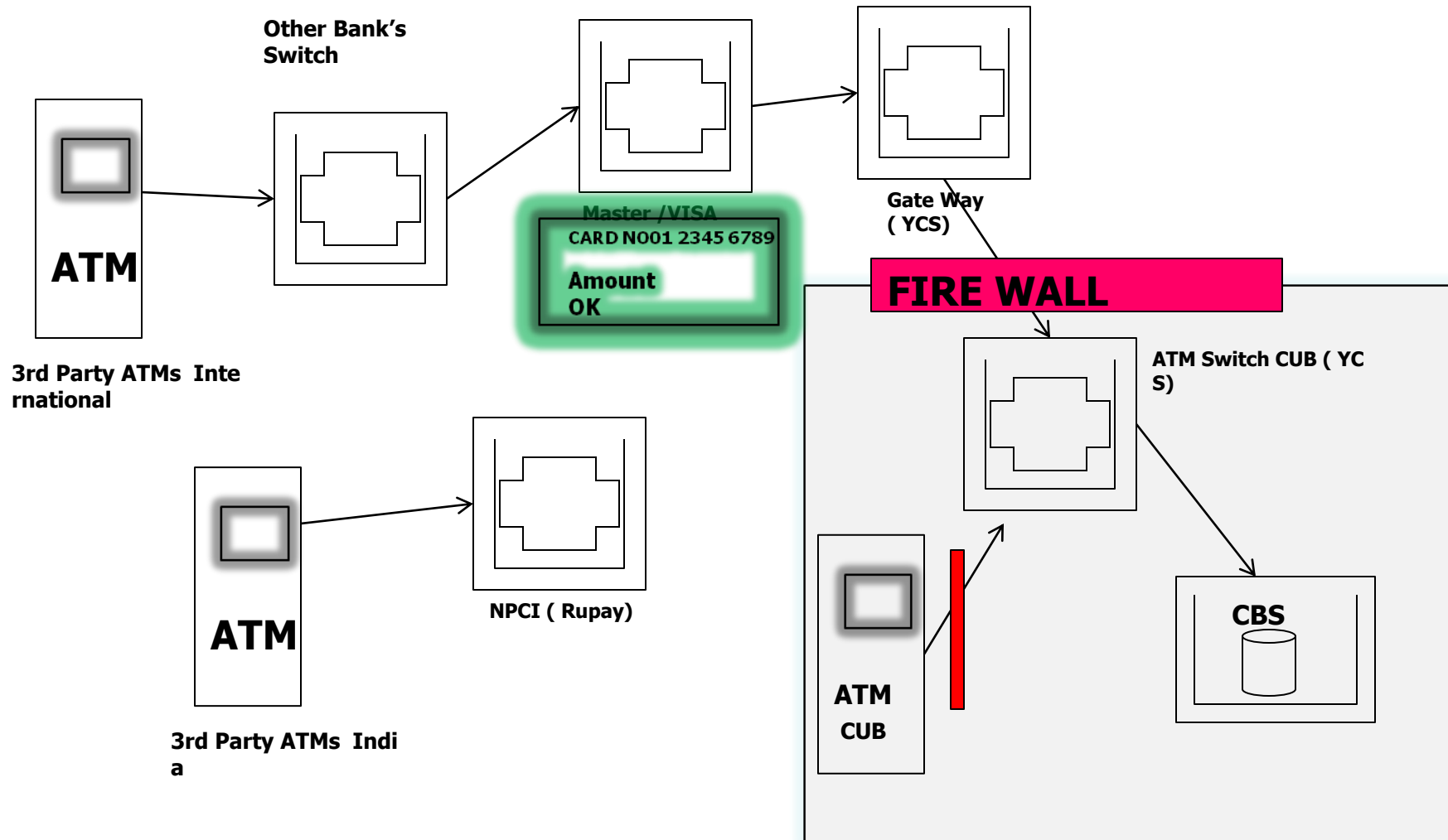

## Probable Scenario / Occurrence of Incident

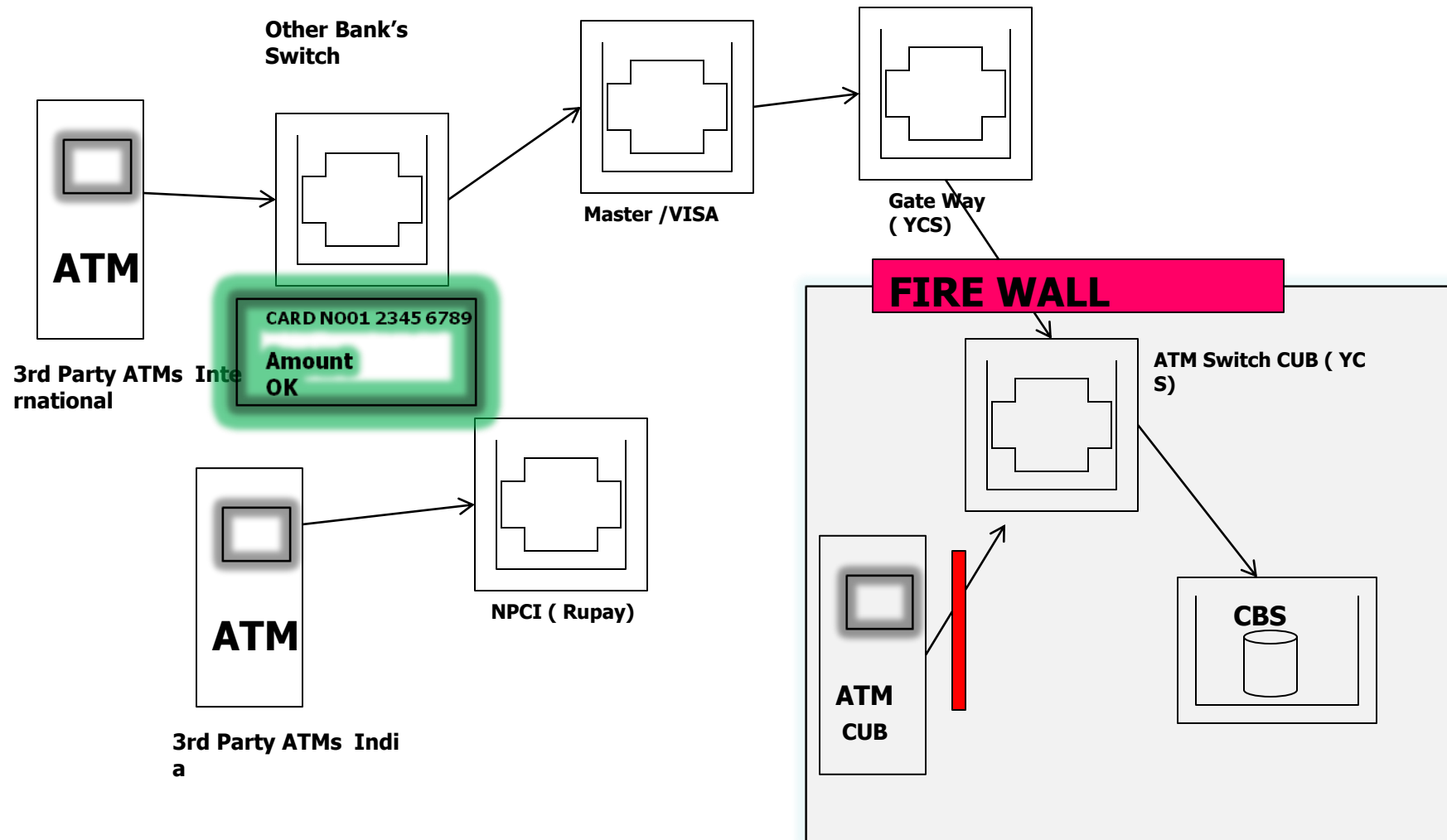

# Probable Scenario / Occurrence of Incident

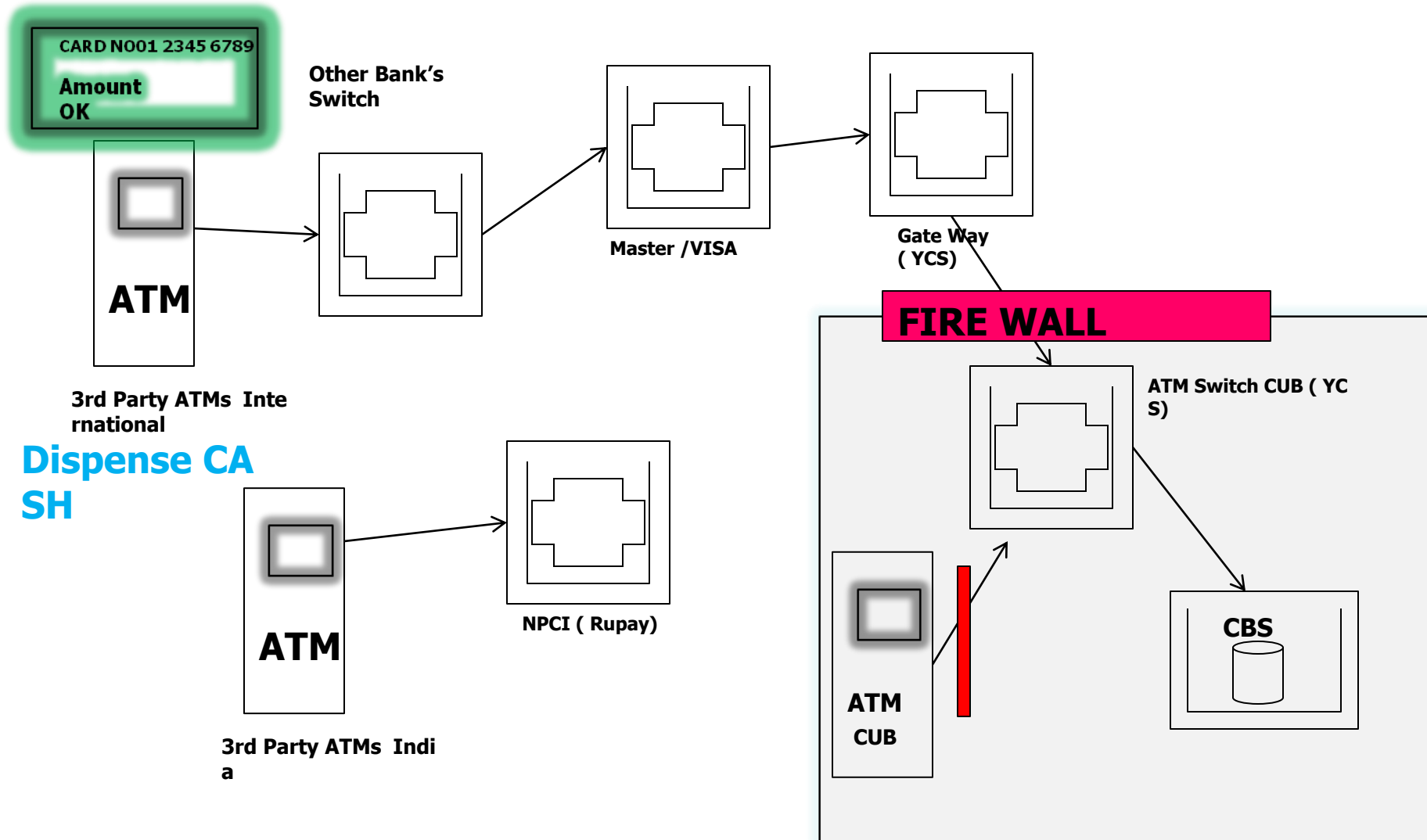

## Probable Scenario / Occurrence of Incident

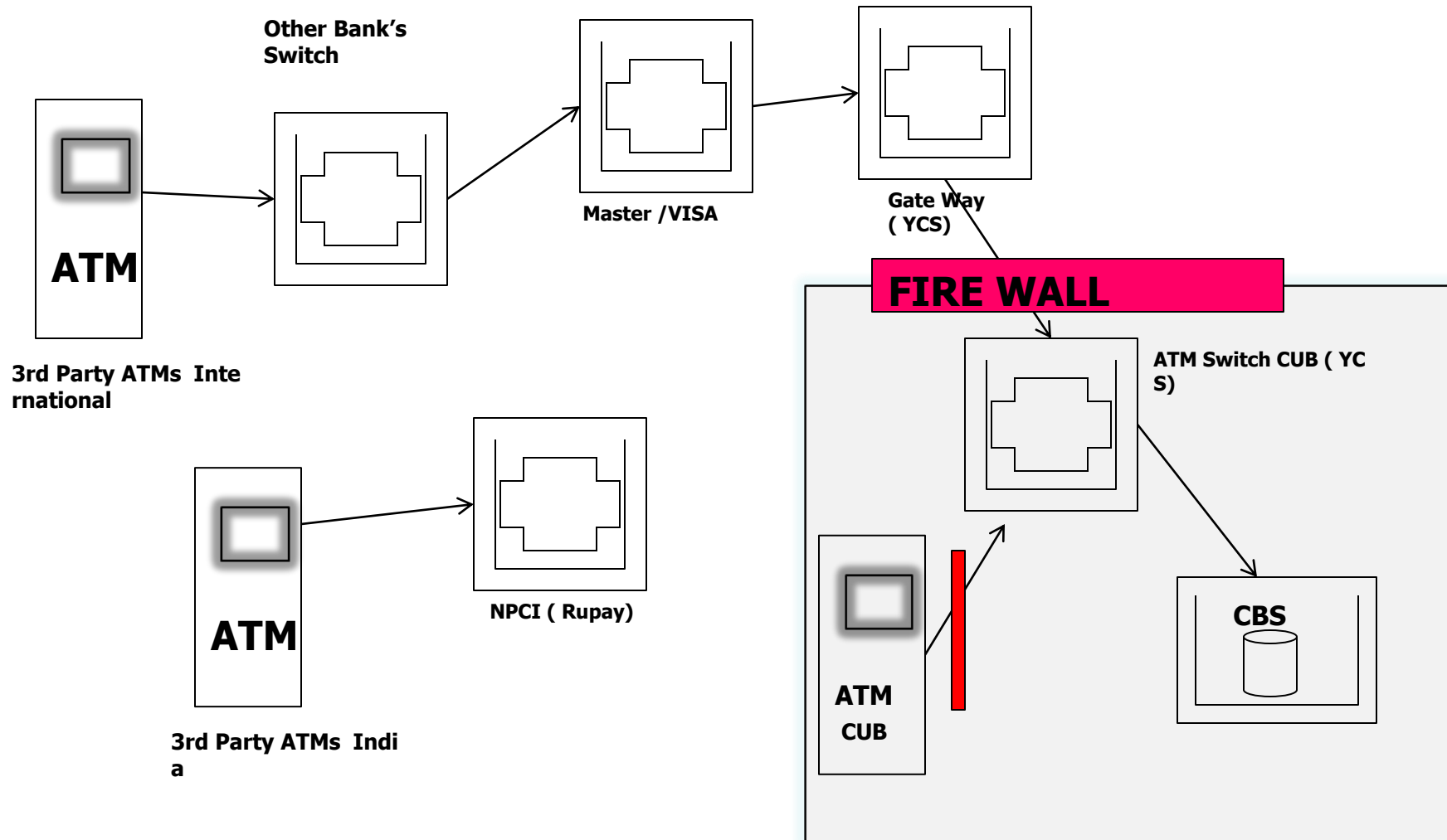

# Probable Scenario / Occurrence of Incident

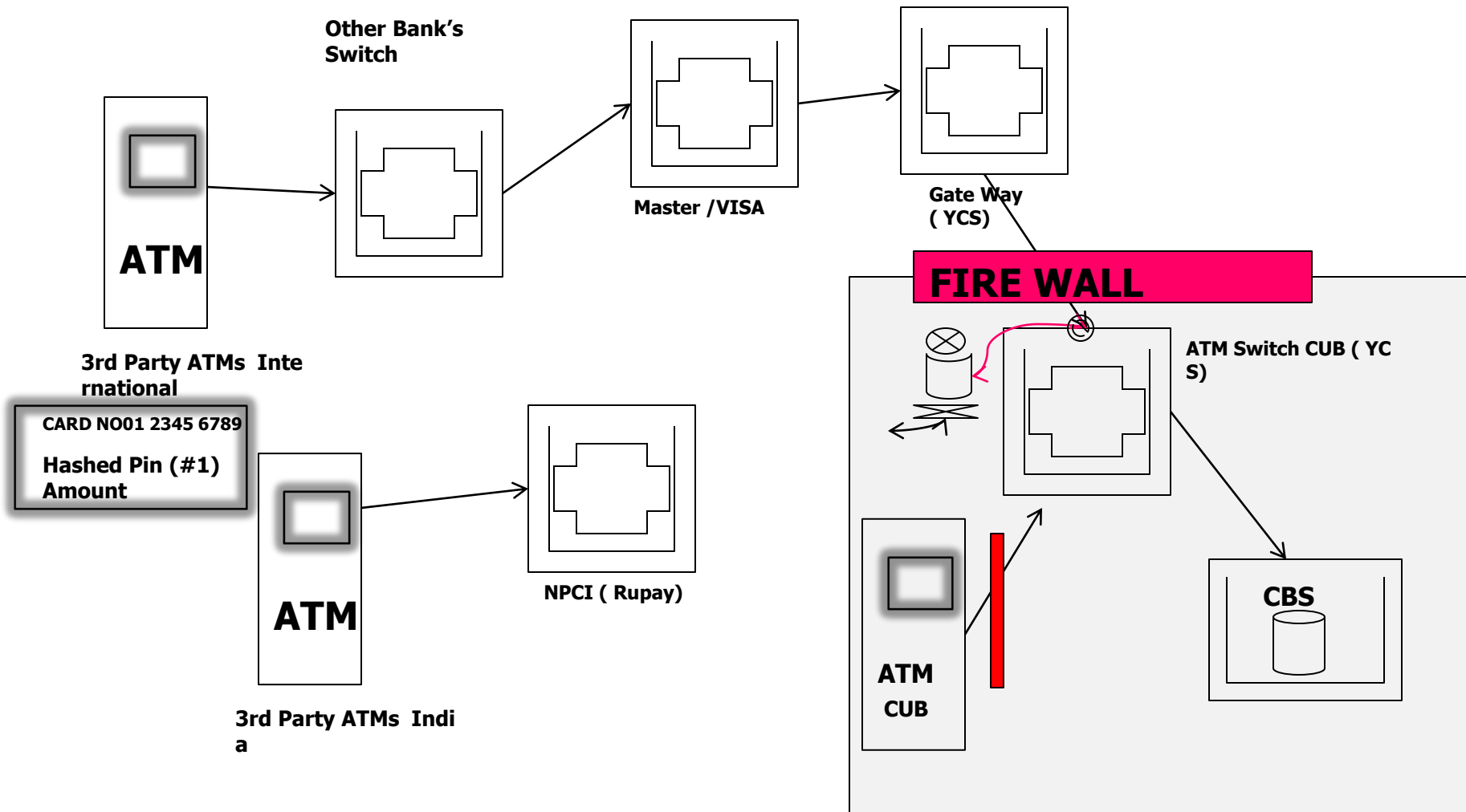



# Probable Scenario / Occurrence of Incident

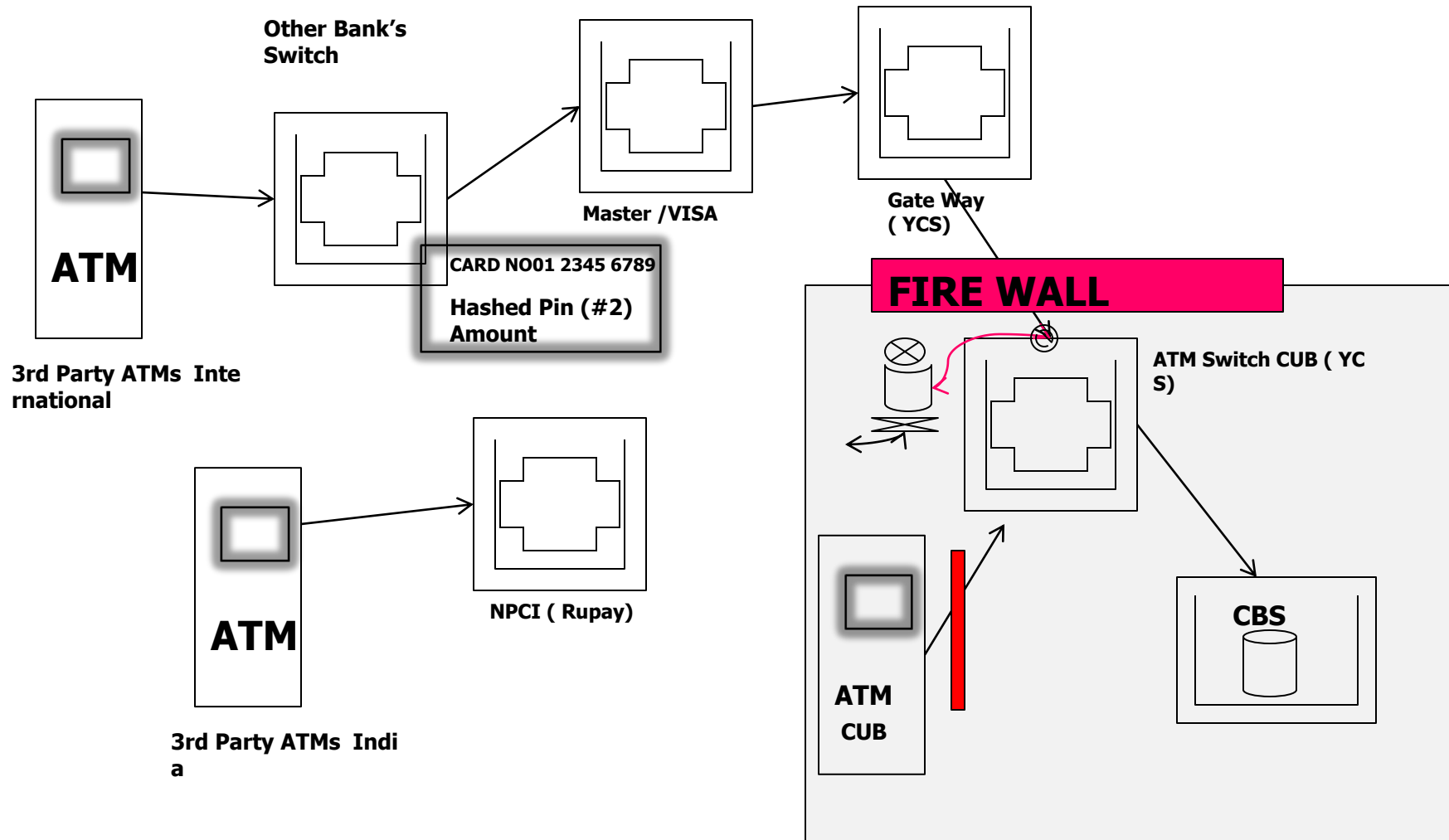

# Probable Scenario / Occurrence of Incident

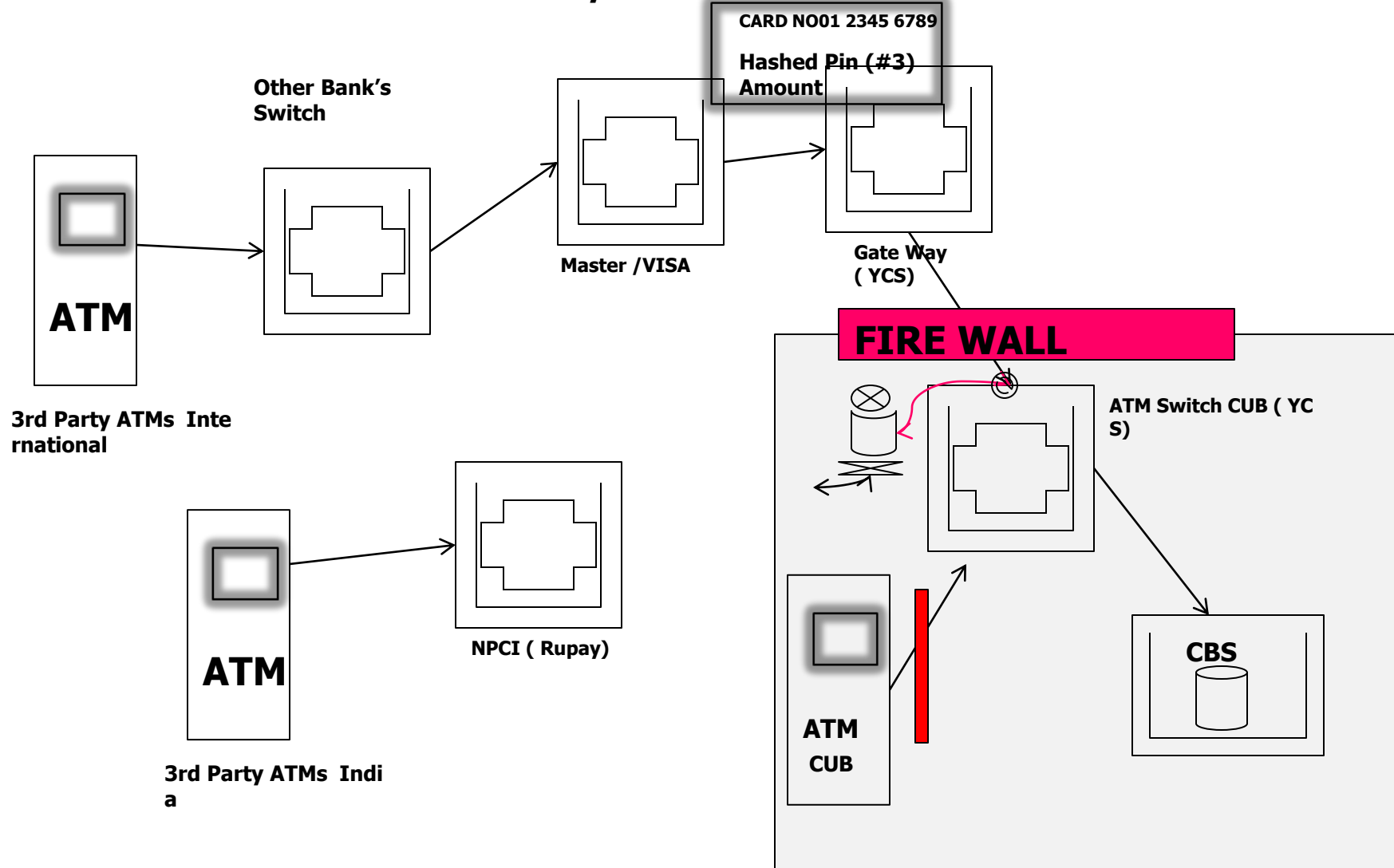

# Probable Scenario / Occurrence of Incident

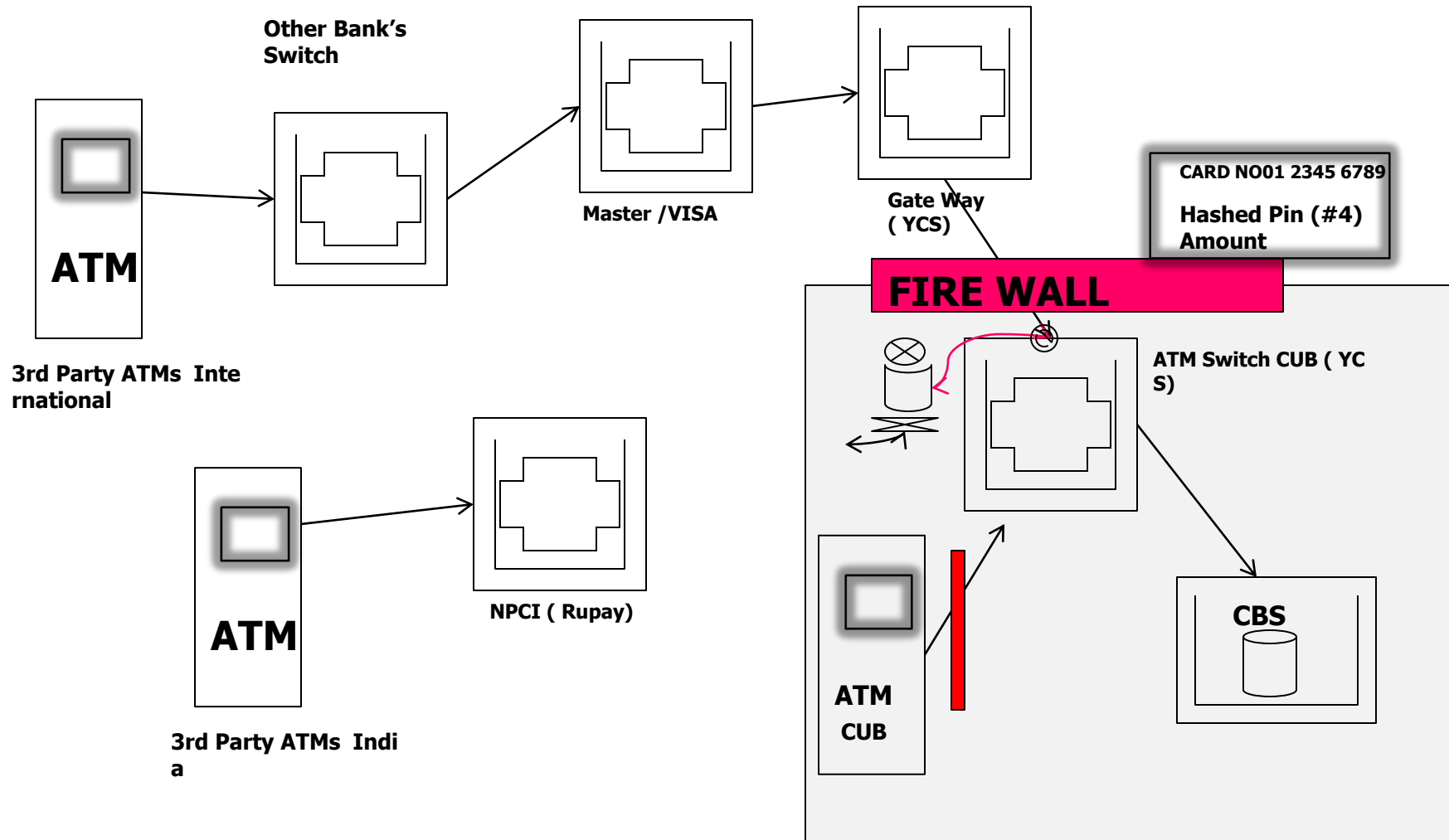

# Probable Scenario / Occurrence of Incident

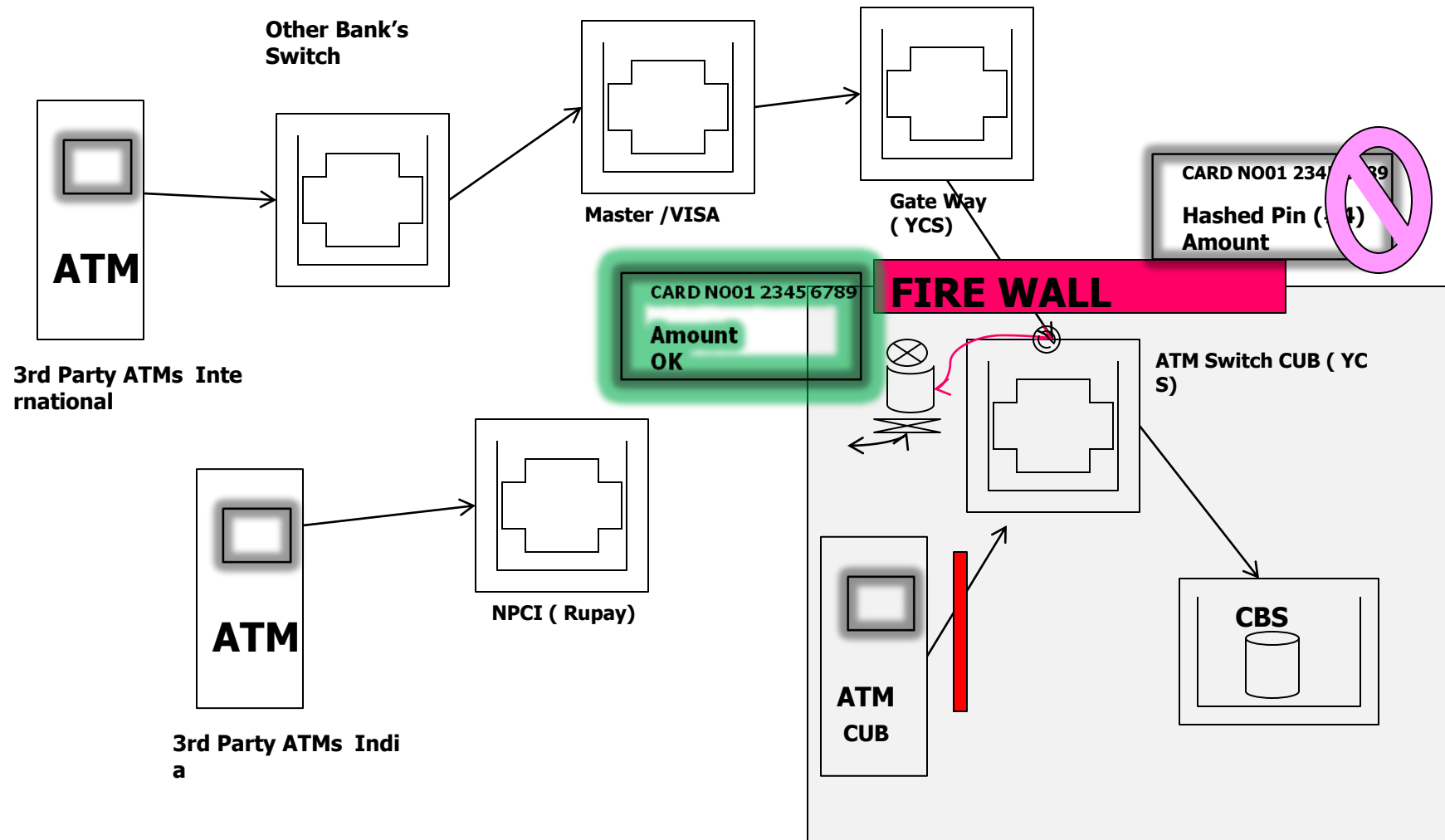

# Probable Scenario / Occurrence of Incident

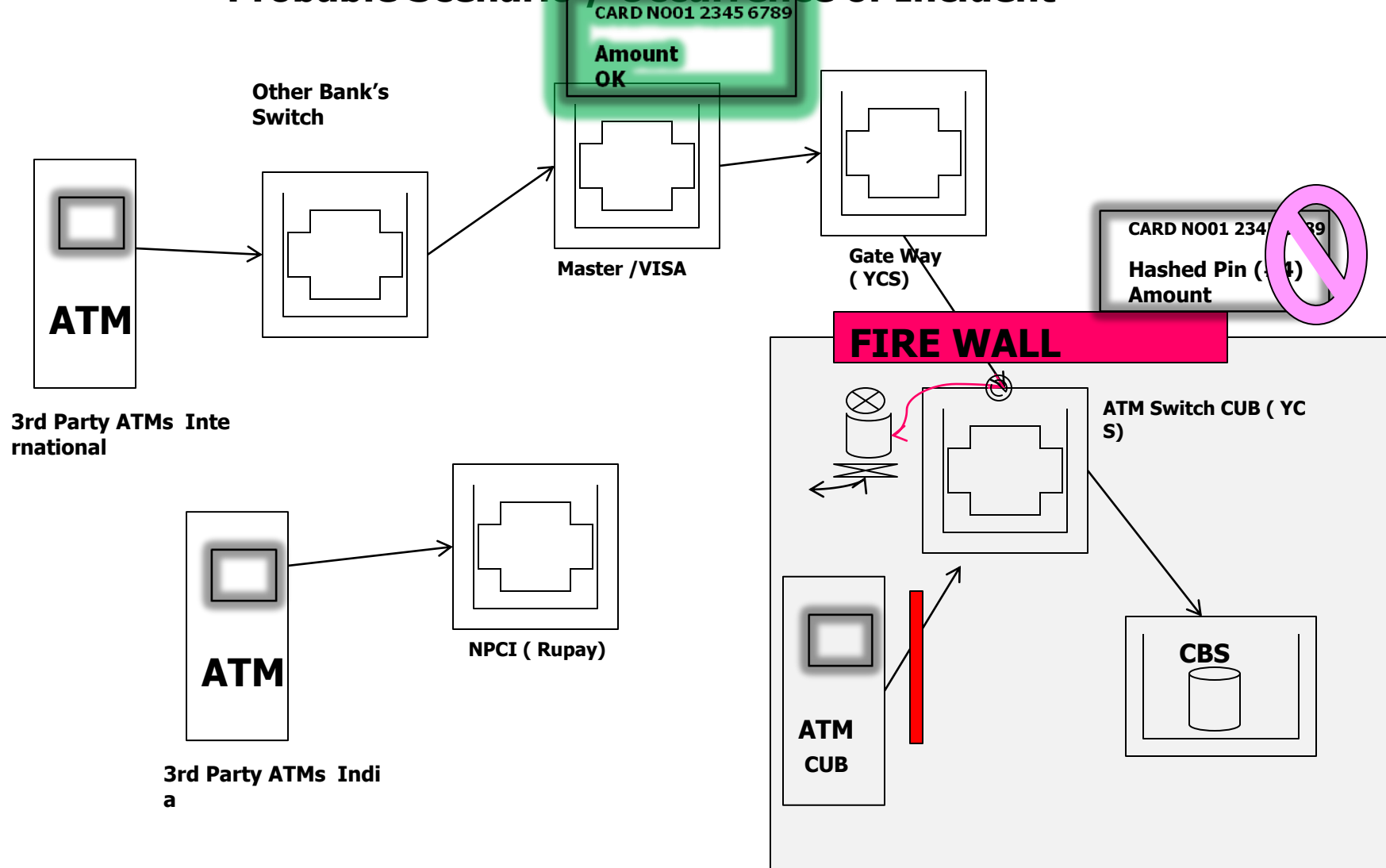



# Probable Scenario / Occurrence of Incident

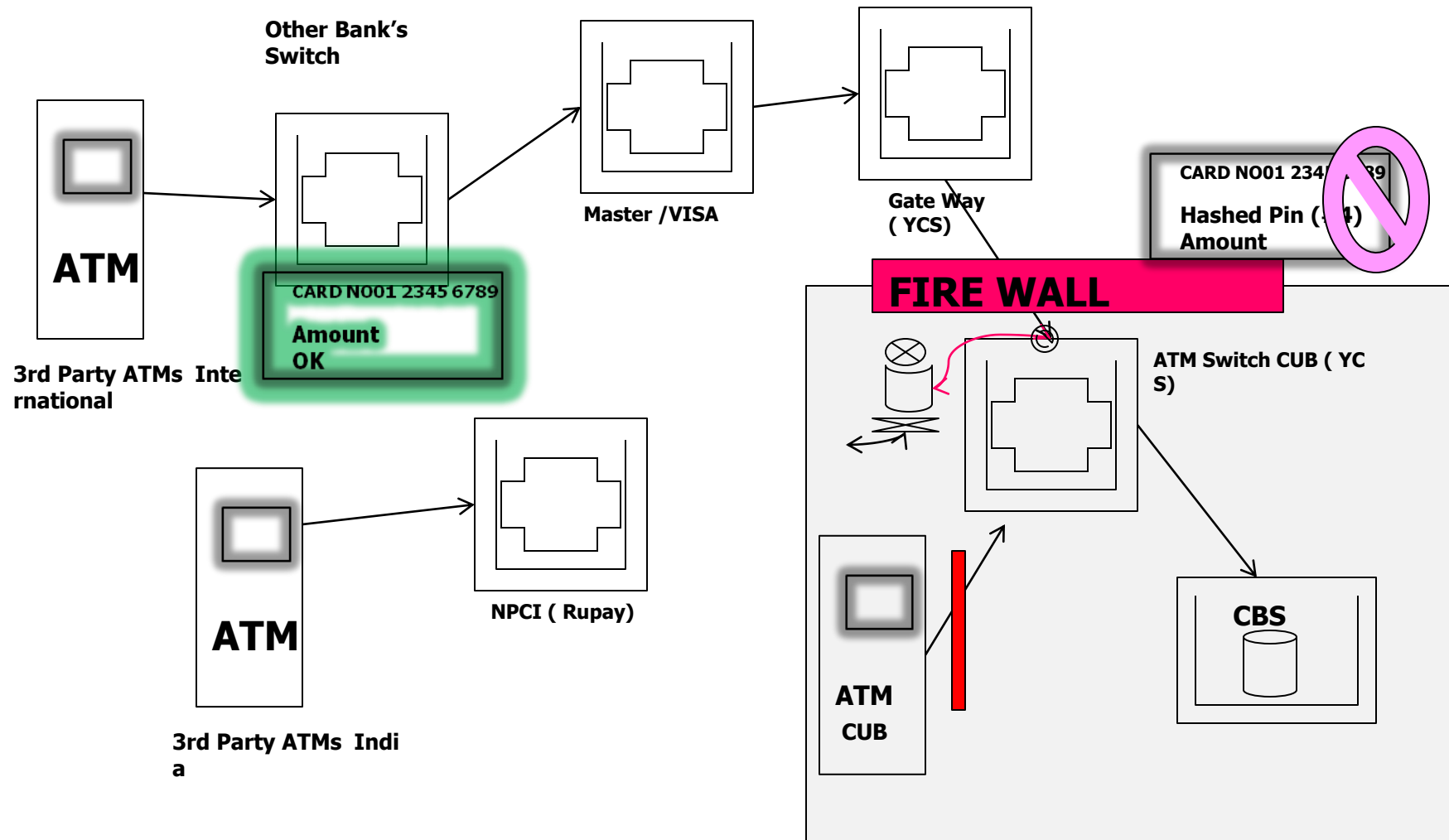

# Probable Scenario / Occurrence of Incident

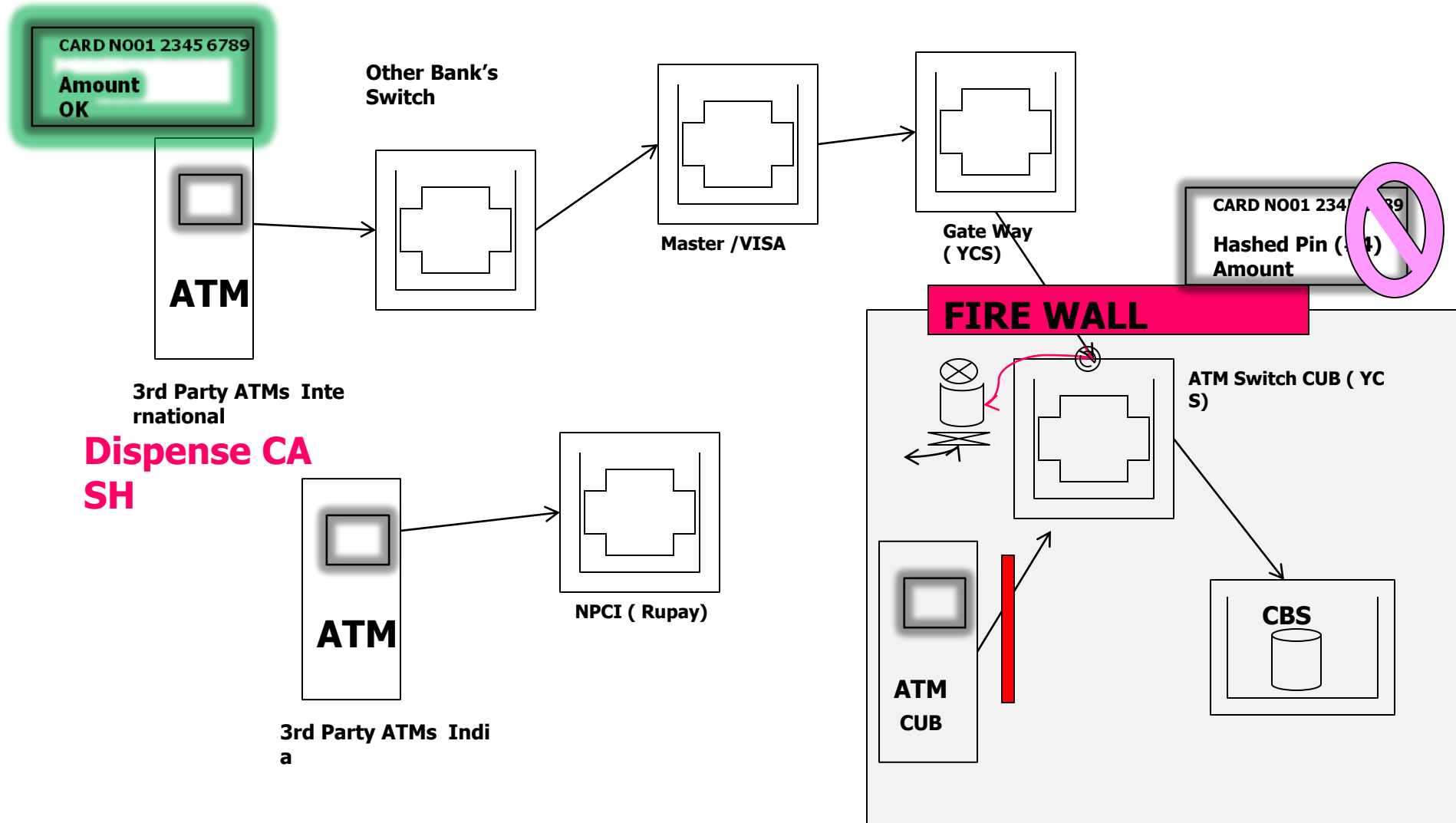

# Probable Scenario / Occurrence of Incident

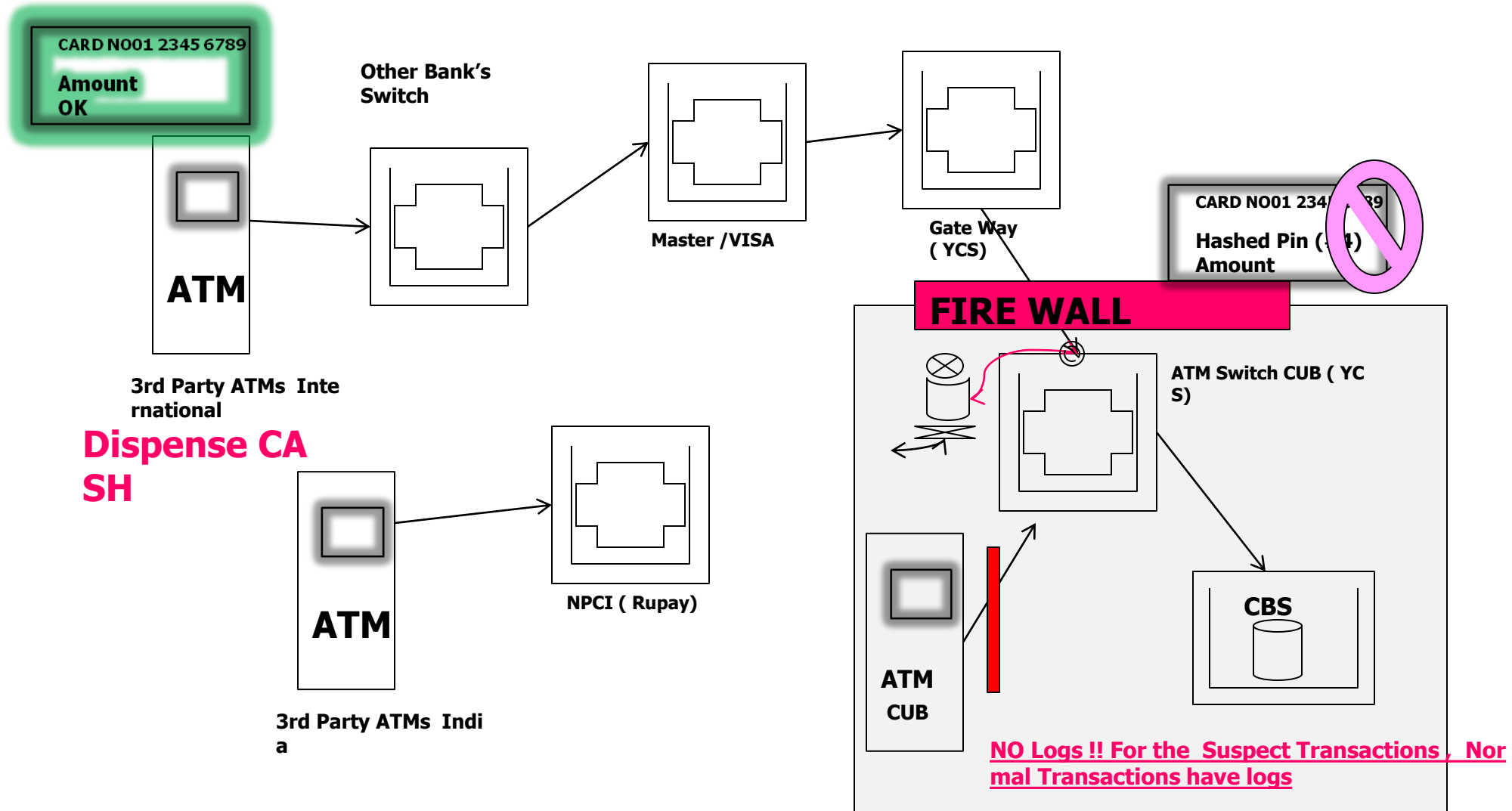

### Countries in which transactions have been executed

<b>S.No</b>	<b>Country</b>
1	AUSTRALIA
2	BELARUS
3	BELIZE
4	BULGARIA
5	CANADA
6	CANADIAN - QUEBE
7	CYPRUS
8	CZECH REPUBLIC
9	UNITED STATES
10	DOMINICAN REPUBLIC
11	ESTONIA
12	FRANCE
13	SPAIN
14	UKRAINE
15	UNITED KINGDOM
17	INDIA

<b>S.No</b>	<b>Country</b>
16	GHANA
17	GREECE
18	INDONESIA
19	ISRAEL
20	ITALY
21	LATVIA
22	LITHUANIA
23	MEXICO
24	PHILIPPINES
25	POLAND
26	RUSSIA
27	TURKEY
28	UNITED ARAB EMIRATES

1 1





boisslockerroom



0  
Posts

57  
Followers

0  
Following

## Bois Locker Room 2.0

Let's start this again.

But this time join the group with fake accounts so no one can expose u.

/ri'kɒnɪsəns/ - re-con-nais-sance

# reconnaissance

*(noun) the act of reconnoitring (especially to gain information about an enemy or potential enemy)*

Tip: you can create your own flashcards by adding this video to favourite list  
Support me by liking / leaving a comment if it helped you

© learn2pronounce.com



WHENEVER YOU  
GET A FRIEND  
REQUEST FROM  
A BEAUTIFUL  
GIRL, DO NOT  
ACCEPT HIM





## Privacy Settings and Tools

<b>Your Activity</b>	Who can see your future posts?	Friends	Edit
	Review all your posts and things you're tagged in		Use Activity Log
	Limit the audience for posts you've shared with friends of friends or Public?		Limit Past Posts
<b>How People Find and Contact You</b>	Who can send you friend requests?	Everyone	Edit
	Who can see your friends list?	Public	Edit
	Who can look you up using the email address you provided?	Everyone	Edit
	Who can look you up using the phone number you provided?	Friends	Edit
	Do you want search engines outside of Facebook to link to your profile?	Yes	Edit





# Tips for avoiding a Social Engineering Attack

## ✔ **LIMIT PUBLIC INFORMATION:**

Limit the amount of personal information that you share online.

## ✔ **BE SKEPTICAL:**

Always question requests for sensitive information.

## ✔ **TRUST BUT VERIFY:**

Don't share information with people you don't know unless you can verify their identity.

## ✔ **CALL THEM BACK:**

Through the main switchboard if possible.

## ✔ **NO PASSWORDS OVER THE PHONE:**

Never share your password with anyone over the phone.



Which was  
the **first** programmable,  
electronic, general-  
purpose **digital computer**





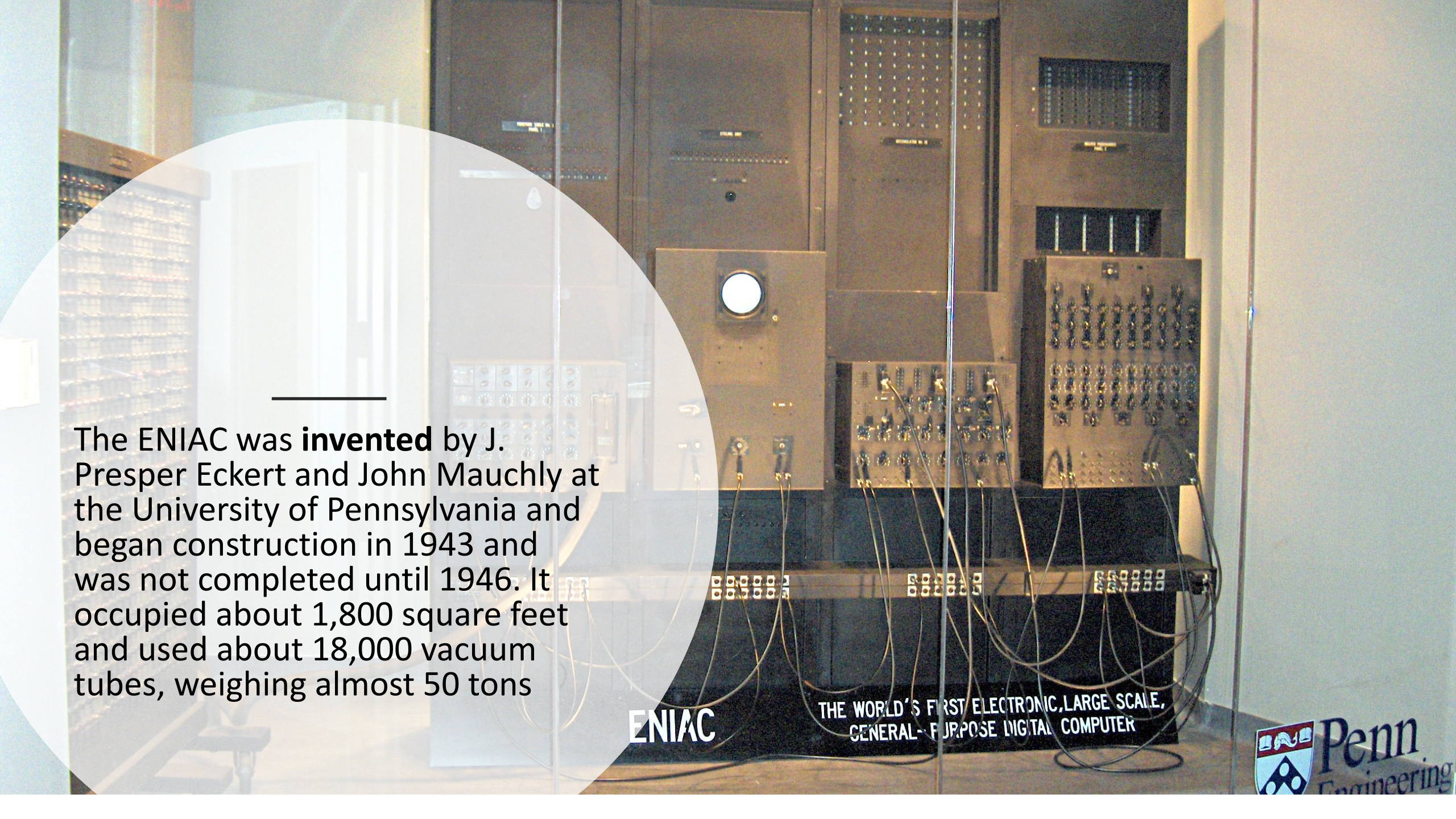

The ENIAC was **invented** by J. Presper Eckert and John Mauchly at the University of Pennsylvania and began construction in 1943 and was not completed until 1946. It occupied about 1,800 square feet and used about 18,000 vacuum tubes, weighing almost 50 tons

ENIAC

THE WORLD'S FIRST ELECTRONIC, LARGE SCALE,  
GENERAL-PURPOSE DIGITAL COMPUTER









## INTERNET - INSTALL MONITORING & FILTERING PROGRAMS



### Anti Social

Are you curious to find out how much you use your cell phone compared to other people? AntiSocial is designed to not only help you understand what 'normal usage' looks like, but to give you the tools to manage, block and control your cell phone usage so that you can unplug, minimize distractions and focus on the things that matter.



### On Ward

We are on a mission to help restore Tech-Life Balance by developing scalable, affordable solutions that give each of us the ability to change our compulsive behaviors free of judgement and stigma.

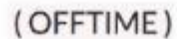

### OFF TIME

( OFFTIME ) helps you to focus and to unplug to be creative - thanks to smart app blocking, communications filter and insights into your smartphone usage.



### Quality Time

Quality Time is a leading developer of family computing platforms, Cloud-based parental control and time management solutions for phones and tablets in this era of mobile hyper connectivity.

## Period Prediction

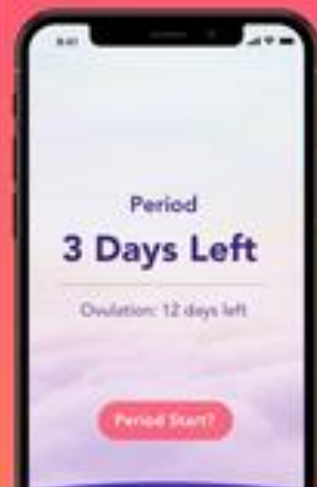

100 MILLION  
USER'S CHOICE

## Accurate Calendar



## Daily Health Notes

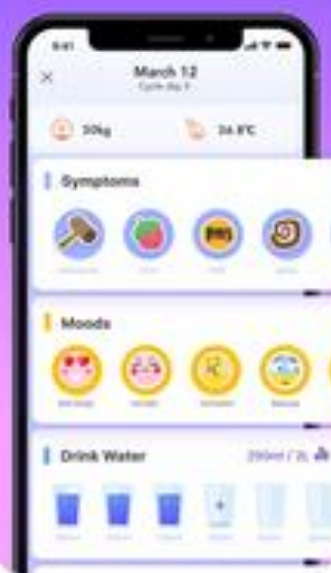

## Cycle History









Analyze suspicious files and URLs to detect types of malware, automatically share them with the security community

FILE

URL

SEARCH



By submitting data below, you are agreeing to our [Terms of Service](#) and [Privacy Policy](#), and to the **sharing of your Sample submission with the security community**. Please do not submit any personal information; VirusTotal is not responsible for the contents of your submission. [Learn more](#).





Home

Notify me



Domain search

Who's been pwned

Passwords

API

About

Donate  

# ';---have i been pwned?

Check if you have an account that has been compromised in a data breach

pwned?



**Ananth Prabhu G** PhD, Post Doctoral Fellow  
Co-Authors : **Adv Prashant Jhala**  
**Yashavantha Kumar KN** DySP

[www.cybersafegirl.com](http://www.cybersafegirl.com)



# Certificate of Completion



Certificate No : ..... Valid upto : .....

This is to certify that ..... has  
successfully completed course on Cyber Safety  
and has secured ..... Grade.



Date : .....

Authorized signatory  
(Ananth Prabhu G)

## Neck and Neck problem

- Did you know that your head weighs around 04 or 05 kg? All supported by some pretty small bones in your neck! A Quick look at biomechanic of the body shows that when you are slouched over a phone at 45 degree angle.its equivalent to placing 22kg of stress on the neck! This often translates into headache and pain down the back....consider your posture! 



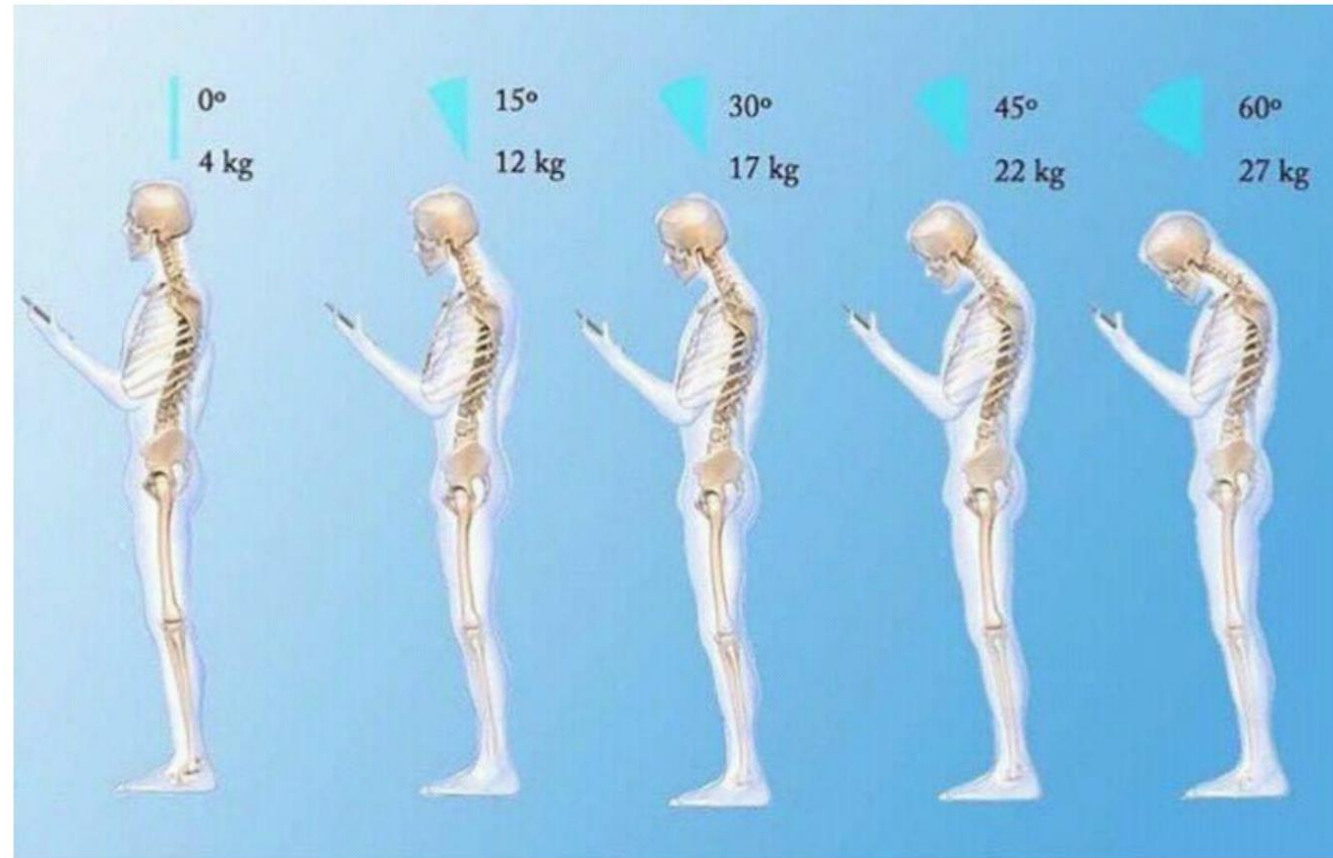





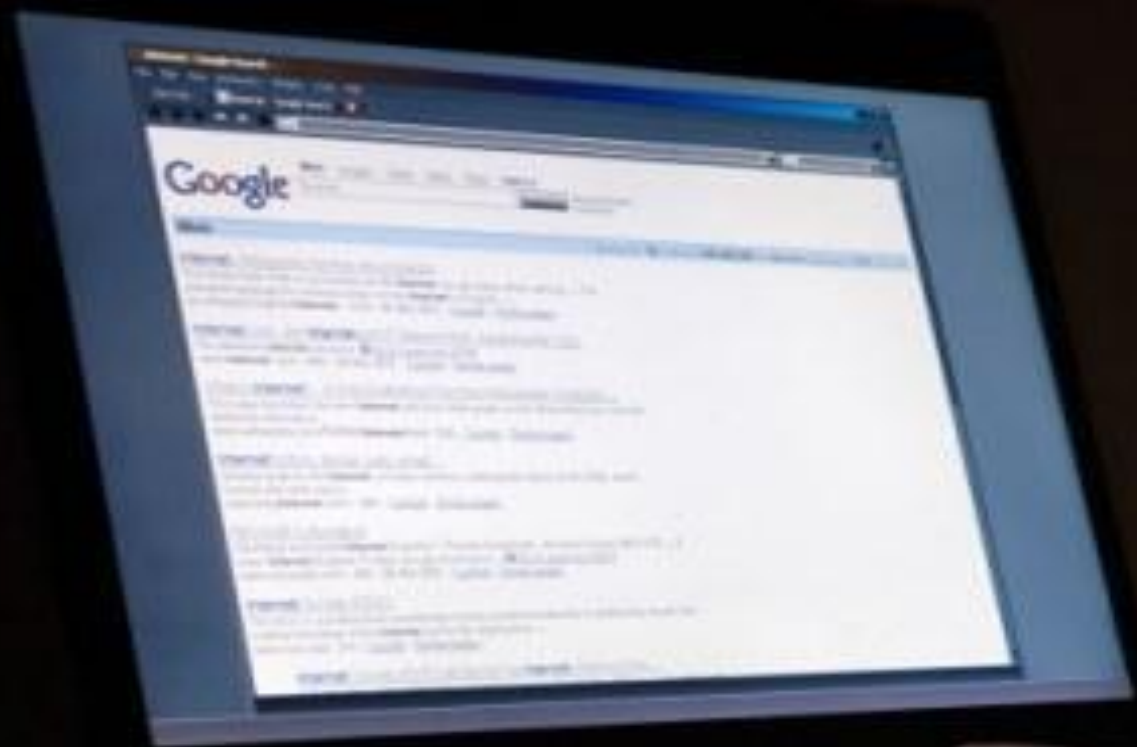

ANY  
QUESTIONS?





## **Dr. Ananth Prabhu G**

Professor- Sahyadri

Cyber Law Adjunct Faculty- Karnataka Judicial Academy

Cyber Security Trainer- Karnataka Police Academy

Director- SurePass Academy

**+91 8951511111**

**[www.fb.com/educatorananth](http://www.fb.com/educatorananth)**



**CYBER**   
**PATRIOT**